

FUEL TANK CAPACITY	U.S.	METRIC
Total (including reserve)	2.8 gallons	10.6 liters
Reserve	0.55 gallons	2.08 liters

CARBURETOR ADJUSTMENTS	
Engine Idle Speed (regular)	1200 RPM
Engine Idle Speed (fast)	2000 RPM

CARBURETOR JET SIZES	
Main Jet	166
Slow Jet	42

ITEM	TORQUE		NOTES
Air box cover to air box	4-6 in-lbs	0.5-0.7 Nm	Page 4-13
Air box to crankcase	10-12 ft-lbs	14-16 Nm	Page 4-13
Battery cables to terminals	60-96 in-lbs	7-11 Nm	Page 4-6
Enrichener stay plate	13-23 in-lbs	2-3 Nm	Page 4-15
Fuel cap flange to fuel tank	20-22 in-lbs	2-3 Nm	Page 4-10
Fuel tank to T-shaped bracket	6-8 ft-lbs	8-11 Nm	Page 4-6
Fuel valve to fuel tank	12-14 in-lbs	1-2 Nm	Page 4-8
Tank cover to T-shaped bracket	30-36 in-lbs	3-4 Nm	Page 4-6
Throttle position sensor	13-23 in-lbs	2-3 Nm	Page 4-24
Triangular bracket to air box	3-5 ft-lbs	4-7 Nm	Page 4-13
Vent tube fitting	40-60 in-lbs	5-7 Nm	Page 4-10
Ventrui ring to carburetor flange	18-22 in-lbs	1.5-1.8 Nm	Page 4-13

Table 4-1. Fuel System Troubleshooting

OVERFLOW TROUBLESHOOTING	
Check for: <ol style="list-style-type: none"> 1. Restricted fuel tank vent system. 2. Loose float bowl screws. 3. Damaged float bowl O-ring. 4. Damaged or leaking float assembly. 5. Particle contamination in fuel inlet fitting cavity. 6. Worn or dirty inlet valve or seat. 7. Improper fuel level in float bowl. 	Remedy: <ol style="list-style-type: none"> 1. Correct restricted hose. Replace vapor vent valve. 2. Tighten screws. 3. Replace O-ring. 4. Replace float assembly. 5. Clean and clear cavity and fuel supply tract. 6. Clean or replace valve and clean seat. 7. Adjust float tab for correct fuel level.
POOR IDLING	
Check for: <ol style="list-style-type: none"> 1. Idle speed improperly adjusted. 2. Inlet system air leak (faster idling). 3. Loose low speed jet. 4. Contaminated or plugged low speed system. 5. Enrichener valve not seated or leaking. 	Remedy: <ol style="list-style-type: none"> 1. Adjust operating idle speed. 2. Correct as required. 3. Tighten jet. 4. Clean, clear and correct as required. 5. Adjust, clean or replace.
POOR FUEL ECONOMY	
Check for: <ol style="list-style-type: none"> 1. Enrichener valve not seated or leaking. 2. Dirty air cleaner filter element. 3. Restricted fuel tank vent system. 4. High speed riding style. 5. Idle speed improperly adjusted. 6. Loose jets. 7. Fuel level too high. 8. Plugged or restricted bowl vent. 9. Worn or damaged needle or needle jet. 10. Vacuum piston assembly malfunction. 11. Plugged air jets or passages. 	Remedy: <ol style="list-style-type: none"> 1. Adjust, clean or replace. 2. Replace as required. 3. Correct restricted hose. Replace vapor vent valve. 4. Modify riding habits. 5. Adjust operating idle speed. 6. Tighten jets. 7. Adjust float tab for correct fuel level. 8. Clean and clear passages. 9. Replace needle or needle jet. 10. See Table 4-2. 11. Clean, clear and correct as required.
POOR ACCELERATION	
Check for: <ol style="list-style-type: none"> 1. Throttle cables misaligned. 2. Inlet system air leak. 3. Restricted fuel tank vent system. 4. Restricted fuel supply passages. 5. Plugged bowl vent or overflow. 6. Enrichener valve not seated or leaking. 7. Worn or damaged needle or needle jet. 8. Vacuum piston malfunction. 9. Plugged jets or passages. 10. Fuel level too low. 	Remedy: <ol style="list-style-type: none"> 1. Adjust throttle cables. 2. Correct as required. 3. Correct restricted hose. Replace vapor vent valve. 4. Correct and clear restriction. 5. Clean and clear passages. 6. Adjust, clean or replace. 7. Replace assembly. 8. See Table 4-2. 9. Clean and clear as required. 10. Adjust float tab for correct fuel level.

Table 4-1. Fuel System Troubleshooting

HARD STARTING	
Check for:	Remedy:
<ol style="list-style-type: none"> 1. Enrichener system plugged, not properly functioning or improperly operated. 2. Inlet system air leak. 3. Restricted fuel supply. 4. Fuel overflow. 5. Plugged slow jet or passages. 	<ol style="list-style-type: none"> 1. Clean, adjust or replace. 2. Correct as required. 3. Correct fuel supply or passages. 4. See OVERFLOW TROUBLESHOOTING above. 5. Clean, clear and correct as required.
POOR PERFORMANCE ON ROAD	
Check for:	Remedy:
<ol style="list-style-type: none"> 1. Idle speed improperly adjusted. 2. Inlet system air leak. 3. Restricted fuel tank vent system. 4. Dirty or damaged air cleaner element. 5. Enrichener valve not seated or leaking. 6. Restricted fuel supply tract. 7. Plugged bowl vent or overflow. 8. Loose or plugged fuel and air jets or passages. 9. Worn or damaged needle or needle jet. 10. Vacuum piston assembly malfunction. 	<ol style="list-style-type: none"> 1. Adjust operating idle speed. 2. Correct as required. 3. Correct restricted hose. Replace vapor vent valve. 4. Replace. 5. Adjust, clean or replace. 6. Correct and clear restriction. 7. Clean and clear passages. 8. Clean, clear and correct as required. 9. Replace assembly. 10. See Table 4-2.
POOR HIGH-SPEED PERFORMANCE	
Check for:	Remedy:
<ol style="list-style-type: none"> 1. Inlet system air leak. 2. Enrichener valve not seated or leaking. 3. Restricted fuel tank vent system. 4. Restricted fuel supply tract. 5. Dirty or damaged air cleaner element. 6. Plugged bowl, vent or overflow. 7. Worn or damaged needle or needle jet. 8. Vacuum piston assembly malfunction. 9. Loose or plugged main jets or passages. 10. Improper fuel level. 	<ol style="list-style-type: none"> 1. Clean or replace. 2. Adjust, clean or replace. 3. Correct restricted hose. Replace vapor vent valve. 4. Correct and clean restriction. 5. Replace. 6. Clean and clear passages. 7. Replace assembly. 8. See Table 4-2. 9. Clean, clear and correct as required. 10. Adjust float level.

Table 4-2. Vacuum Piston Assembly Troubleshooting

PISTON DOES NOT RISE PROPERLY	
Check for:	Remedy:
<ol style="list-style-type: none"> 1. Piston atmosphere vent blocked. 2. Diaphragm cap loose, damaged or leaking. 3. Spring binding. 4. Diaphragm pinched at lip groove. 5. Torn diaphragm. 6. Piston binding. 7. Piston vacuum passage plugged. 	<ol style="list-style-type: none"> 1. Clear vent. 2. Tighten or replace cap. 3. Correct or replace spring. 4. Reposition diaphragm lip. 5. Replace piston diaphragm assembly. 6. Clean piston slides and body or replace piston. 7. Clean and clear passage.
PISTON DOES NOT CLOSE PROPERLY	
Check for:	Remedy:
<ol style="list-style-type: none"> 1. Spring damaged. 2. Piston binding. 3. Piston diaphragm ring dirty or damaged. 	<ol style="list-style-type: none"> 1. Replace spring. 2. Clean piston slides and body or replace piston. 3. Clean or replace piston.

REMOVAL

Fuel Tank Cover

⚠ WARNING

Gasoline is extremely flammable and highly explosive. When servicing the fuel system, do not smoke or allow open flame or sparks in the vicinity. Inadequate safety precautions could result in death or serious injury.

1. Remove seat. Depress latch at bottom and pull seat up and back to remove. See Figure 4-1.

⚠ WARNING

To protect against shock and accidental start-up of vehicle, disconnect the negative battery cable before proceeding. Inadequate safety precautions could result in death or serious injury.

2. Unthread bolt and remove battery negative cable (black) from battery negative (-) terminal.
3. At rear of fuel tank, remove flange bolt (with nylon washer) to release tank cover from clip nut on T-shaped mounting bracket. See A of Figure 4-2.
4. Carefully cut small cable strap and pull vent tube from fitting at front of fuel cap flange.
5. Remove oil dipstick from threaded hole in frame backbone (just rear of steering head). Remove mounting ring from around threaded hole.
6. Remove tank cover and set aside.
7. Install oil dipstick back into threaded hole in frame backbone.

Fuel Tank

8. Rotate the 3-position valve handle on the fuel valve to the fully vertical position to shut the gasoline supply to the carburetor OFF. See A of Figure 4-5.

⚠ WARNING

Some gasoline will drain from the outlet hose when disconnected from the fuel valve. Thoroughly wipe up any spilled fuel immediately. Dispose of rags in a suitable manner. Gasoline is extremely flammable and highly explosive. Inadequate safety precautions could result in death or serious injury.

9. Turn slotted screw to loosen band clamp on outlet fitting at side of fuel valve. Pull hose from fitting.
10. At rear of fuel tank, remove remaining two flange bolts to release T-shaped mounting bracket from frame backbone. See B of Figure 4-2.
11. Remove left side airbox cover. See 4.3 AIR CLEANER.
12. Moving to front of vehicle, pry rubber stops from weld studs on each side of frame backbone. See A and B of Figure 4-3.
13. Raise rear of fuel tank and slide assembly rearward to remove from frame.

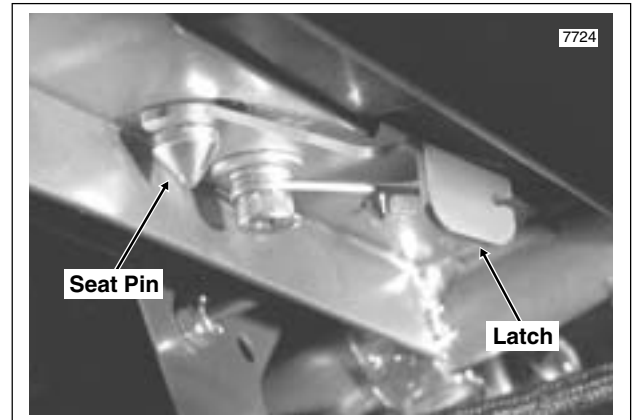

Figure 4-1. Remove Seat

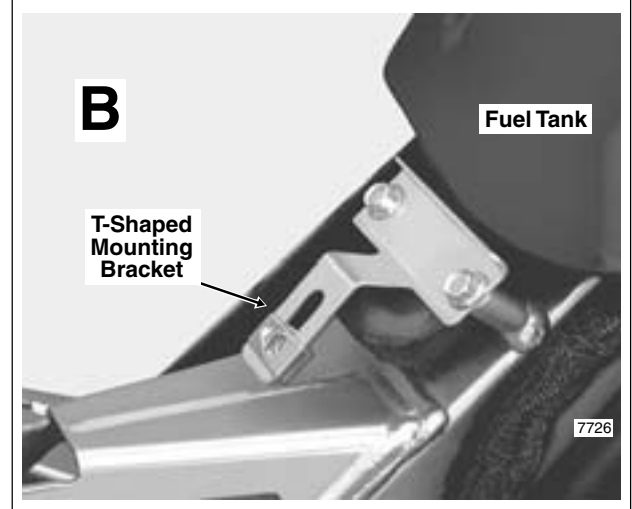
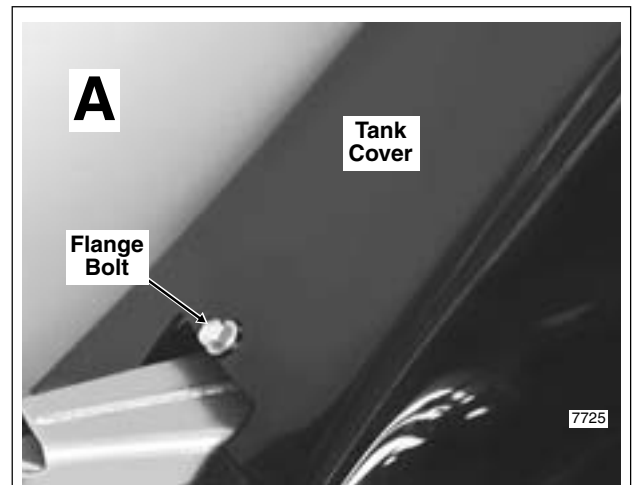

Figure 4-2. Remove Tank Cover Fuel Tank

INSTALLATION

Fuel Tank

1. Place fuel tank into position on frame backbone.
2. Standing at front of vehicle, push rubber stops onto weld studs on each side of frame backbone. Using a rubber mallet, tap stops until fully seated. See A and B of [Figure 4-3](#).
3. With the lipped side up, slide two flange bolts through forward holes in T-shaped mounting bracket. Pushing down on rear of tank, start flange bolts into bosses in frame backbone. Alternately tighten flange bolts to 6-8 ft-lbs (8-11 Nm). See B of [Figure 4-2](#).
4. Install airbox cover on left hand side. See [4.3 AIR CLEANER](#).
5. Push hose onto outlet fitting at side of fuel valve. Turn slotted screw to tighten band clamp.

Fuel Tank Cover

6. Remove oil dipstick from threaded hole in frame backbone (just rear of steering head).
7. Install tank cover.
8. At rear of fuel tank, install rear flange bolt (with nylon washer) to fasten tank cover to clip nut on T-shaped mounting bracket. Tighten flange bolt to 30-36 **in-lbs** (3-4 Nm). See A of [Figure 4-2](#).
9. With the lipped side up, place mounting ring over threaded hole in frame backbone. Install oil dipstick into hole.
10. Push vent tube onto nozzle of vent tube fitting. Install small cable strap to fix location. Cut any excess cable strap material.
11. Insert bolt through battery negative cable (black) into threaded hole of battery negative (-) terminal. Tighten bolt to 60-96 **in-lbs** (7-11 Nm).
12. Position seat on frame backbone, so that tongue at bottom engages slot in frame weldment. Push down on rear of seat until spring-loaded latch fully engages groove of seat pin.

WARNING

Pull up on seat to verify that it is properly secured, front and rear. A loose seat may shift during vehicle operation and startle the rider, possibly causing loss of vehicle control that could result in death or serious injury.

FUEL CAP

Removal

1. Locate the fuel filler cap at the top of the fuel tank.
1. Insert finger into depression and lift the locking tab up, so that it is perpendicular to the fuel filler cap.
2. Rotate the locking tab 1/4 turn in a counter-clockwise direction.
3. Pull locking tab to remove fuel filler cap from tank.

4. Observe the warning label at the top of the fuel tank. When refueling, keep fuel level at least one inch below bottom of fuel cap boot. See A of [Figure 4-4](#).

WARNING

Remove the fuel filler cap slowly. Fill fuel tank slowly to prevent fuel spillage. Observe the warning label at the top of the tank. Keep fuel level at least one inch below bottom of fuel cap boot. This allows sufficient air space for fuel expansion. Expansion can cause an overfilled tank to overflow fuel through the filler cap vent onto surrounding areas. After refueling, be sure filler cap is securely tightened. Gasoline is extremely flammable and highly explosive. Inadequate safety precautions could result in death or serious injury.

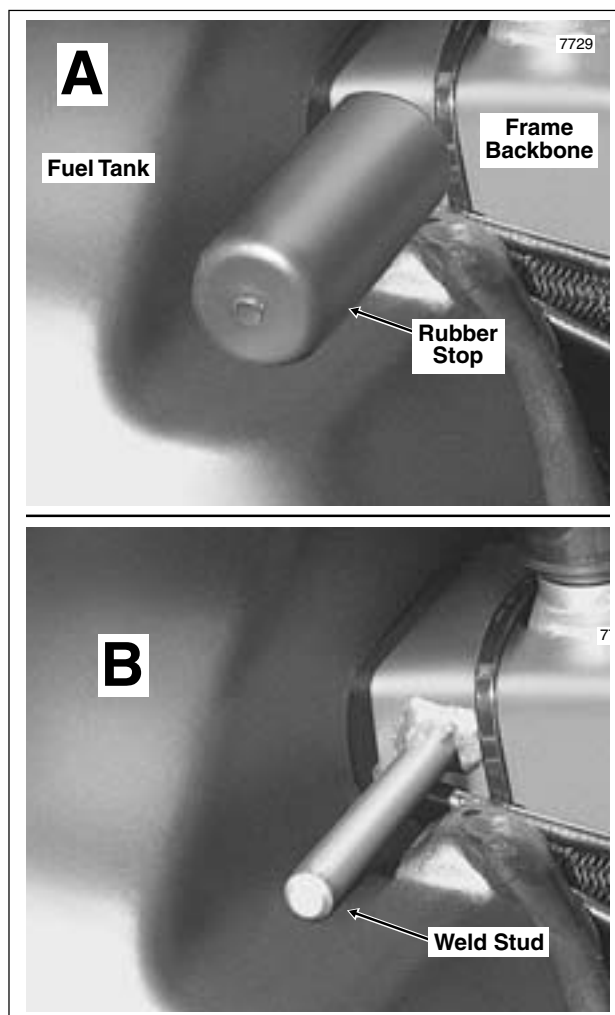

Figure 4-3. Remove Fuel Tank

Installation

1. Inspect O-ring at underside of fuel filler cap for cuts, tears or signs of deterioration. Replace if necessary. See B of [Figure 4-4](#).
2. Place fuel filler cap into tank with the depression at the front.
3. Rotate the locking tab 1/4 turn in a clockwise direction.

- Push locking tab down, so that it is flush with the fuel filler cap.

NOTE

Locking tab should snap down tightly, but not so tight that it becomes too difficult to remove. To increase or decrease the tension required to operate the locking tab, turn the fuel filler cap over and either loosen or tighten the 10mm nut. See B of Figure 4-4.

FUEL SUPPLY VALVE

Operation

The fuel supply valve is located under the fuel tank on the left side of the vehicle. The gasoline supply to the carburetor is dependent upon the position of the valve handle. See upper frame of Figure 4-5.

Turning the 3-position valve handle to the fully vertical position shuts the gasoline supply to the carburetor OFF. Moving the valve handle counter-clockwise to the horizontal position turns the main fuel supply ON. Turning the handle clockwise to the horizontal position accesses the RES(ERVE) supply. See Figure 4-5.

WARNING

To prevent accidental flooding of the engine or surrounding area with gasoline, always turn the fuel supply valve to OFF when the engine is not running. Gasoline is extremely flammable and highly explosive. Inadequate safety precautions could result in death or serious injury.

NOTE

To maintain a reserve supply, do not operate the motorcycle with the valve in the RES(ERVE) position after refueling.

Removal

NOTE

Clean or replace fuel filter strainer every 20,000 miles.

WARNING

Gasoline is extremely flammable and highly explosive. When servicing the fuel system, do not smoke or allow open flame or sparks in the vicinity. Inadequate safety precautions could result in death or serious injury.

- Remove seat. Depress latch at bottom and pull seat up and back to remove. See Figure 4-1.

WARNING

To protect against shock and accidental start-up of vehicle, disconnect the negative battery cable before proceeding. Inadequate safety precautions could result in death or serious injury.

- Unthread bolt and remove battery negative cable (black) from battery negative (-) terminal.
- Drain fuel tank as follows:

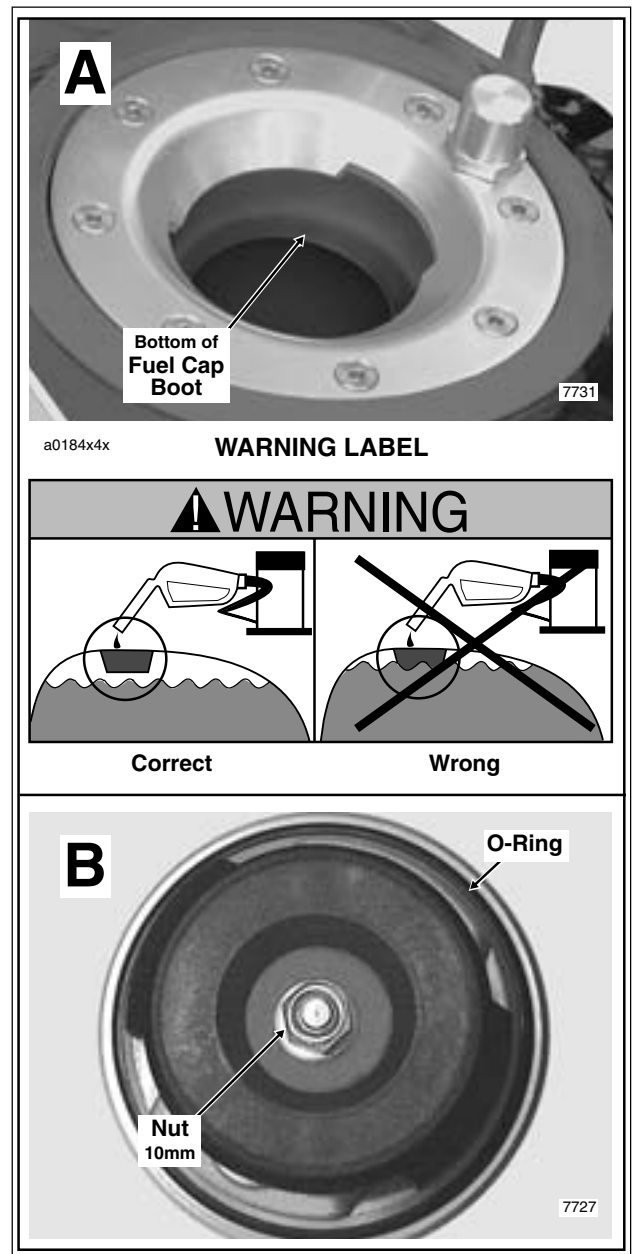

Figure 4-4. Remove Tank Cover/Fuel Tank

- Rotate handle on the fuel supply valve to the fully vertical position to shut the gasoline supply to the carburetor OFF. See A of Figure 4-5.
- Some gasoline will drain from the outlet hose when disconnected from the fuel valve. Thoroughly wipe up any spilt fuel immediately. Dispose of rags in a suitable manner. Gasoline is extremely flammable and highly explosive. Inadequate safety precautions could result in death or serious injury.
- Turn slotted screw to loosen band clamp on outlet fitting at side of fuel valve. Pull hose from fitting.
- Attach length of spare hose to outlet fitting. Place free end of hose into a suitable container.
- Rotate handle of fuel supply valve to RES(ERVE) to start the flow of fuel. See C of Figure 4-5.

- f. Once the fuel tank is completely drained, rotate handle of fuel supply valve to OFF. Remove spare hose from outlet fitting.

⚠ WARNING

Even with the fuel tank completely drained, a small amount of gasoline may leak from the bore when the fuel supply valve is loosened or removed. Thoroughly wipe up any spilt fuel immediately. Dispose of rags in a suitable manner. Gasoline is extremely flammable and highly explosive. Inadequate safety precautions could result in death or serious injury.

4. Remove two allen head screws from fuel valve and pull assembly from fuel tank bore.
5. Remove O-ring from flange of fuel valve assembly. Discard O-ring.
6. Carefully unthread fuel filter strainer from fuel valve assembly. Clean strainer using a suitable solvent. Discard strainer if any damage is found.

Installation

1. Carefully thread fuel filter strainer onto fuel valve assembly.
2. Install **new** O-ring into groove on flange of fuel valve assembly.
3. Insert fuel valve assembly into fuel tank bore and install two allen head screws. Alternately tighten screws to 12-14 **in-lbs** (1-2 Nm).
4. Push hose onto outlet fitting at side of fuel valve. Turn slotted screw to tighten band clamp.
5. Verify that handle of fuel supply valve is in the OFF position and fill the fuel tank.
6. Rotate handle of fuel supply valve to ON and carefully inspect for leaks. Return the valve to the OFF position when finished.
7. Insert bolt through battery negative cable (black) into threaded hole of battery negative (-) terminal. Tighten bolt to 60-96 **in-lbs** (7-11 Nm).
8. Position seat on frame backbone, so that tongue at bottom engages slot in frame weldment. Push down on rear of seat until spring-loaded latch fully engages groove of seat pin.

⚠ WARNING

Pull up on seat to verify that it is properly secured, front and rear. A loose seat may shift during vehicle operation and startle the rider, possibly causing loss of vehicle control that could result in death or serious injury.

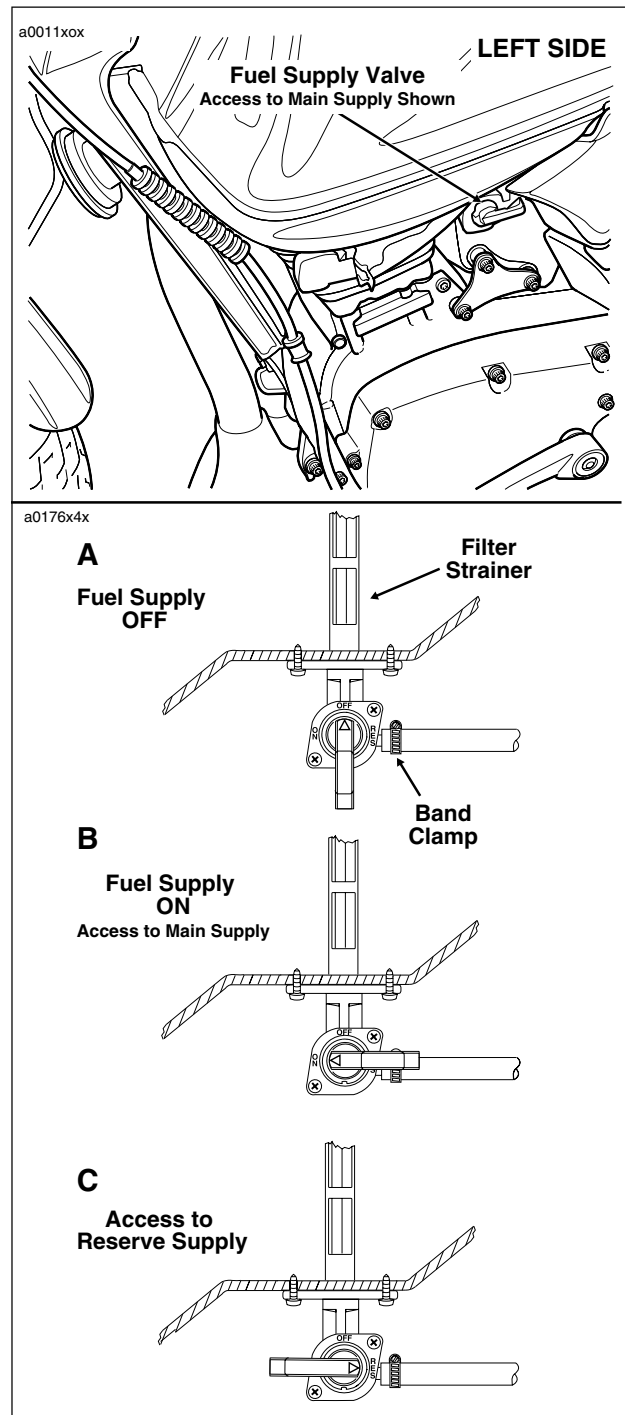

Figure 4-5. Fuel Supply Valve

ROLLOVER VALVE

Removal

WARNING

Gasoline is extremely flammable and highly explosive. When servicing the fuel system, do not smoke or allow open flame or sparks in the vicinity. Inadequate safety precautions could result in death or serious injury.

1. Remove seat. Depress latch at bottom and pull seat up and back to remove. See Figure 4-1.

WARNING

To protect against shock and accidental start-up of vehicle, disconnect the negative battery cable before proceeding. Inadequate safety precautions could result in death or serious injury.

2. Unthread bolt and remove battery negative cable (black) from battery negative (-) terminal.
3. Drain fuel tank as follows:
 - a. Rotate handle on the fuel supply valve to the fully vertical position to shut the gasoline supply to the carburetor OFF. See A of Figure 4-5.

WARNING

Some gasoline will drain from the outlet hose when disconnected from the fuel valve. Thoroughly wipe up any spilt fuel immediately. Dispose of rags in a suitable manner. Gasoline is extremely flammable and highly explosive. Inadequate safety precautions could result in death or serious injury.

- b. Turn slotted screw to loosen band clamp on outlet fitting at side of fuel valve. Pull hose from fitting.
 - c. Attach length of spare hose to outlet fitting. Place free end of hose into a suitable container.
 - d. Rotate handle of fuel supply valve to RES(ERVE) to start the flow of fuel. See C of Figure 4-5.
 - e. Once the fuel tank is completely drained, rotate handle of fuel supply valve to OFF. Remove spare hose from outlet fitting.
4. Insert finger into depression at top of fuel filler cap and lift the locking tab up. Rotate tab 1/4 turn in a counter-clockwise direction, and then pull to remove fuel filler cap from tank.
 5. Carefully cut small cable strap and pull vent tube from fitting at front of fuel cap flange.
 6. Alternately loosen and remove eight fuel cap flange screws in a crosswise pattern. See Figure 4-7.
 7. Insert fingers into filler neck and under fuel cap boot to hold bottom of rollover valve. Rotate hex on vent tube fitting in a counter-clockwise direction and remove.
 8. Keeping fingers at bottom of rollover valve, push on threaded end to remove from holes in fuel cap flange and boot. See A of Figure 4-8. Remove fuel cap flange and boot from fuel tank.

a0177x4x

VEHICLE UPRIGHT

Check ball holds post to one side allowing hydrocarbon vapors to be released to the atmosphere or charcoal canister (California

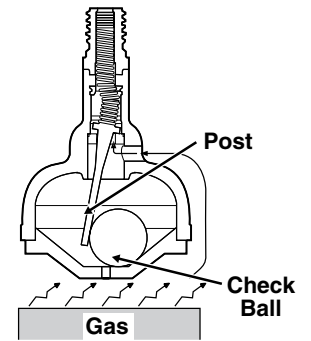

VEHICLE TIPPED

Without influence of check ball, spring forces post to seal opening preventing loss of gasoline through the vent tube.

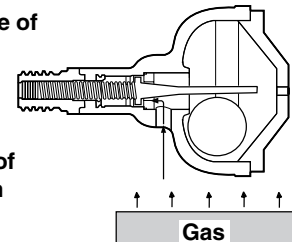

Figure 4-6. Rollover Valve

a0178x4x

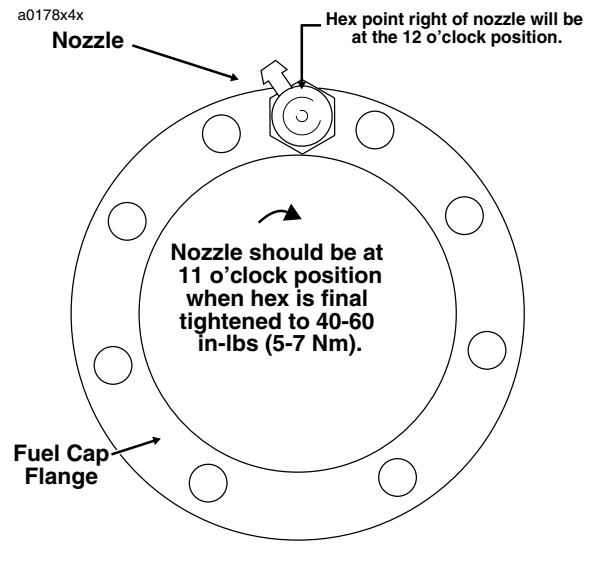

Figure 4-7. Filler Cap Flange Torque Sequence and Vent Tube Fitting Orientation

9. Maintaining hold of rollover valve, remove from hole in fuel tank. See B of Figure 4-8. Exercise caution to avoid dropping valve into fuel tank.
10. Remove O-ring from groove in vent tube fitting. Discard O-ring.
11. Clean old HYLOMAR material from both sides of fuel cap boot, top of fuel tank, and bottom of fuel cap flange.

Installation

1. Install **new** O-ring into groove of vent tube fitting.
2. Spread HYLOMAR on both sides of fuel cap boot confining application to where boot makes contact with top of fuel tank and bottom of fuel cap flange.
3. Holding rollover valve in a vertical position with the threaded end at the top, insert into filler neck pushing threaded end up through hole in fuel tank. See B of Figure 4-8. Exercise caution to avoid dropping valve into fuel tank.
4. With hole in boot aligned with hole in fuel cap flange, place over threaded end of rollover valve. Start vent tube fitting onto threads of rollover valve, but do not tighten.
5. Using a crosswise pattern, alternately tighten eight fuel cap flange screws until snug. See Figure 4-7. Following the same pattern, final tighten screws to 20-22 **in-lbs** (2-3 Nm).
6. Hand tighten vent tube fitting, so that nozzle is at the 11 o'clock position (with hex point to the right of the nozzle at 12 o'clock). See Figure 4-7.

NOTE

If nozzle is not at the 11 o'clock position when hand tightened, loosen the fitting slightly, and reaching into filler neck with two fingers, slightly rotate body of rollover valve in a counter-clockwise direction. Hand tighten fitting again and observe orientation of nozzle. If nozzle is closer, repeat procedure. If further away, rotate body of valve in the opposite direction. A few attempts may be needed to achieve the desired result.

CAUTION

Do not overtighten vent tube fitting or attempt to tighten with standard "click-type" torque wrench. Overtightening fitting can snap off threaded end of rollover valve, possibly causing damaged parts to fall into fuel tank.

7. Using a dial-type torque wrench on hex, final tighten vent tube fitting to 40-60 **in-lbs** (5-7 Nm). Verify that nozzle has not rotated out of 11 o'clock position.
8. Push hose onto outlet fitting at side of fuel supply valve. Turn slotted screw to tighten band clamp.
9. Push vent tube onto nozzle of vent tube fitting. Install small cable strap to fix location. Cut any excess cable strap material.
10. Insert bolt through battery negative cable (black) into threaded hole of battery negative (-) terminal. Tighten bolt to 60-96 **in-lbs** (7-11 Nm).

WARNING

Pull up on seat to verify that it is properly secured, front and rear. A loose seat may shift during vehicle operation and startle the rider, possibly causing loss of vehicle control that could result in death or serious injury.

11. Position seat on frame backbone, so that tongue at bottom engages slot in frame weldment. Push down on rear of seat until spring-loaded latch fully engages groove of seat pin.
12. Verify that handle of fuel supply valve is in the OFF position and fill the fuel tank.

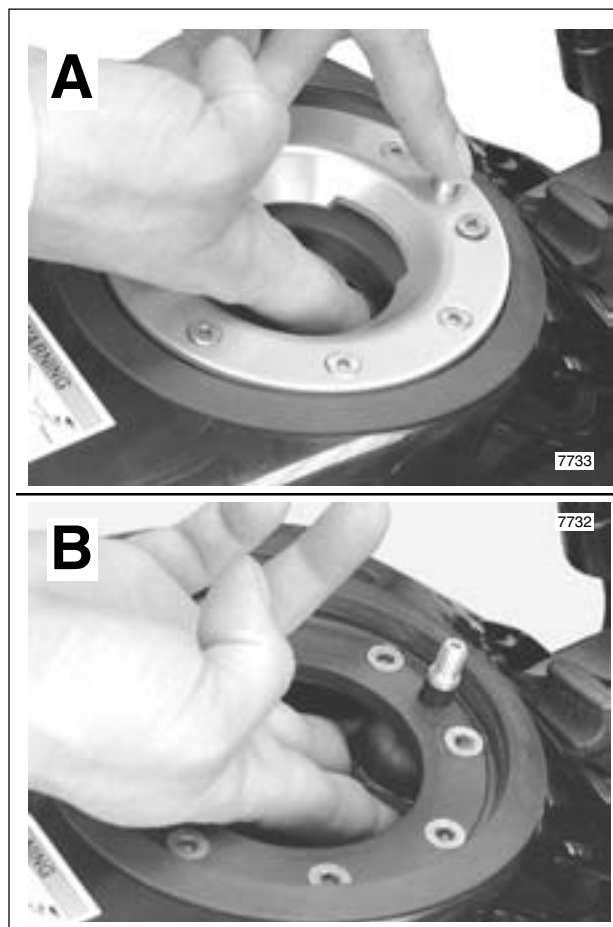

Figure 4-8. Remove Rollover Valve

13. Rotate handle of fuel supply valve to ON and carefully inspect for leaks. Return the valve to the OFF position when finished.

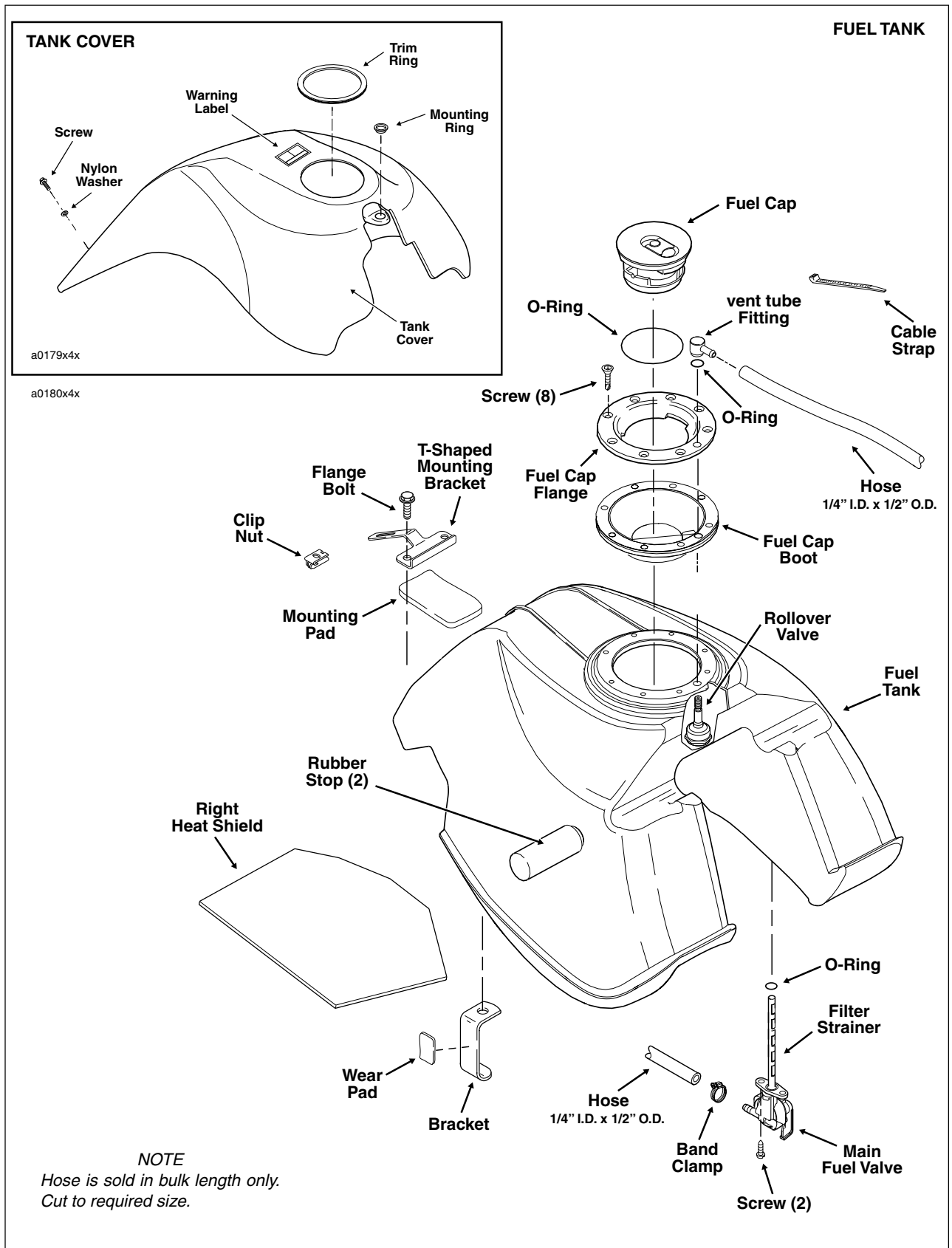

Figure 4-9. Fuel Tank Assembly

GENERAL

The air cleaner prevents foreign material from entering the carburetor and engine, trapping airborne dust and dirt in the filter element. Service the air cleaner filter element every 10,000 miles (16,000 km), or more often if the motorcycle is run in a dusty environment. Replace the element every 30,000 miles (48,000 km).

REMOVAL

1. Release five latches around perimeter of air box cover. See [Figure 4-10](#).
2. Remove single Phillips screw at bottom of air box cover (7 o'clock position).
3. Pull cover from air box.
4. Pull conical shaped filter from air box.
5. Squeeze wings on spring clamp with pliers and pull PCV outlet hose from fixed position on allen head screw (gold) at top of venturi ring. Remove screw with spacer.
6. Remove remaining two allen head screws to free venturi ring from carburetor flange.
7. Remove hex screw at bottom of air box (6 o'clock position) to release bracket from crankcase hole.
8. Moving to left side of vehicle, remove two flange bolts to release side of air box from triangular shaped bracket. Do not remove bottom bolt to crankcase. See [Figure 4-12](#).

CAUTION

Do not take bolt in and out of the crankcase unless necessary. Since the potential for stripping always exists during removal and installation, leave the bolt intact to avoid possible damage to the crankcase.

9. Returning to the right side of the vehicle, carefully pull out air box. When partially removed, detach PCV outlet hose from middle fitting on 3-way connector.
10. Remove gasket from inboard side of air box. Discard gasket.

CLEANING AND INSPECTION

1. Thoroughly clean air cleaner cover and backplate.
2. Replace the filter element if damaged or if filter media cannot be adequately cleaned.

WARNING

Do not use gasoline or solvents to clean the filter element. Volatile or flammable cleaning agents may cause an intake system fire, which could result in death or serious injury.

3. Wash the filter element (and hose connections) in warm, soapy water. To remove soot and carbon, soak element for 30 minutes in warm water with mild detergent.

WARNING

Compressed air can pierce the skin and cause injury. Never use your hand to check for leaks or to determine air flow rates. Wear safety glasses to shield your eyes from flying dirt and debris. Failure to comply could result in death or serious injury.

4. Dry the filter element using low pressure compressed air (32 psi/221 kPa maximum). Rotate the element while moving air nozzle up and down the element exterior. Do not rap the element on a hard surface.
5. Hold the filter element up to a strong light source. The element can be considered sufficiently clean if light is uniformly visible through the media.
6. Inspect all hose connections for cuts, tears, holes or signs of deterioration. Replace as necessary. Direct compressed air through hoses to verify that they are not plugged.

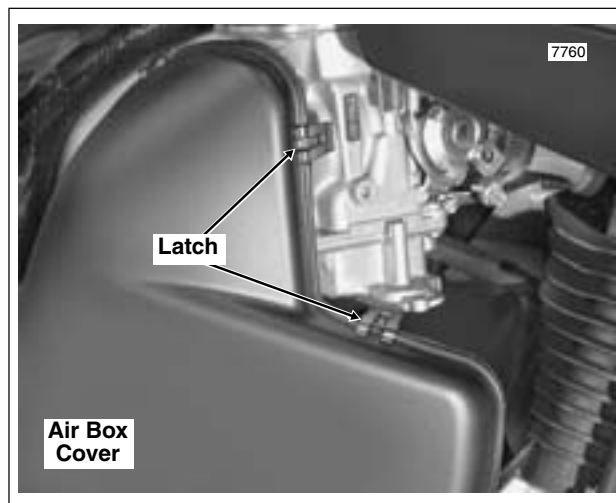

Figure 4-10. Release Air Box Cover Latches

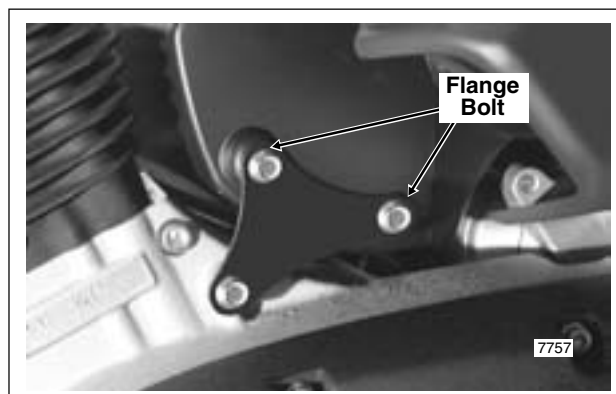

Figure 4-11. Remove Air Box From Bracket

INSTALLATION

1. Obtain a **new** carburetor gasket. Remove the protective paper and place the sticky side of the gasket against the back of the airbox. Use care to align the holes in the gasket with the slotted holes in the airbox.
2. Standing on the right side of the vehicle, start air box into opening below and to the rear of the carburetor. When partially installed, push PCV outlet hose onto middle fitting of 3-way connector.
3. Moving to opposite side of vehicle, apply a small dab of Loctite Low Strength Threadlocker 222 (Purple) to threads of two flange bolts. Slide bolts through top two holes of triangular bracket and install into left side of air box. Alternately tighten screws to 3-5 ft-lbs (4-7 Nm).
4. Returning to right side of vehicle, align slots in air box with holes in carburetor flange.
5. Apply a small dab of Loctite Medium Strength Threadlocker 243 (blue) to threads of two short allen head screws. With the flat edge at the top, align holes in venturi ring with holes in carburetor flange. Install screws in the 5 o'clock and 9 o'clock positions. Alternately tighten screws to 18-22 **in-lbs** (1.5-1.8 Nm).
6. Slide spacer onto longer allen head screw (gold), if removed. Apply a small dab of Loctite Medium Strength Threadlocker 243 (blue) to threads of screw and install into remaining hole in venturi ring (2 o'clock position). Tighten screw to 18-22 **in-lbs** (1.5-1.8 Nm).
7. Squeeze wings on spring clamp with pliers and push free end of PCV outlet hose over head of gold screw (and spacer) to fix position. See Figure 4-13.
8. Apply one drop of Loctite High Strength Threadlocker 262 (red) to threads of hex screw. Install screw at bottom of air box (6 o'clock position) to secure air box bracket to crankcase hole. Tighten screw to 10-12 ft-lbs (14-16 Nm).
9. With the larger OD inboard, install conical shaped filter into air box.
10. Taking note of index pin on inboard side of cover and small depression at tip of cone, position cover onto air box so that pin engages depression. See Figure 4-14.
11. Lock five latches around perimeter of air box cover.
12. Install Phillips screw at bottom of air box cover (7 o'clock position) to secure cover to air box. Tighten screw to 4-6 **in-lbs** (0.5-0.7 Nm).



Figure 4-12. Fix Hose End Onto Allen Head Screw

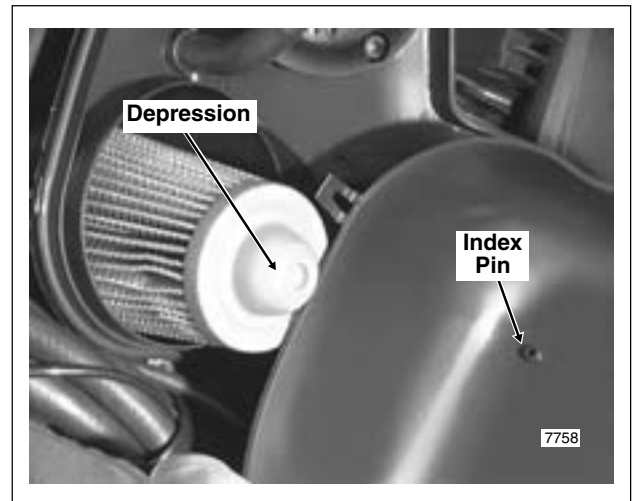

Figure 4-13. Install Air Box Cover

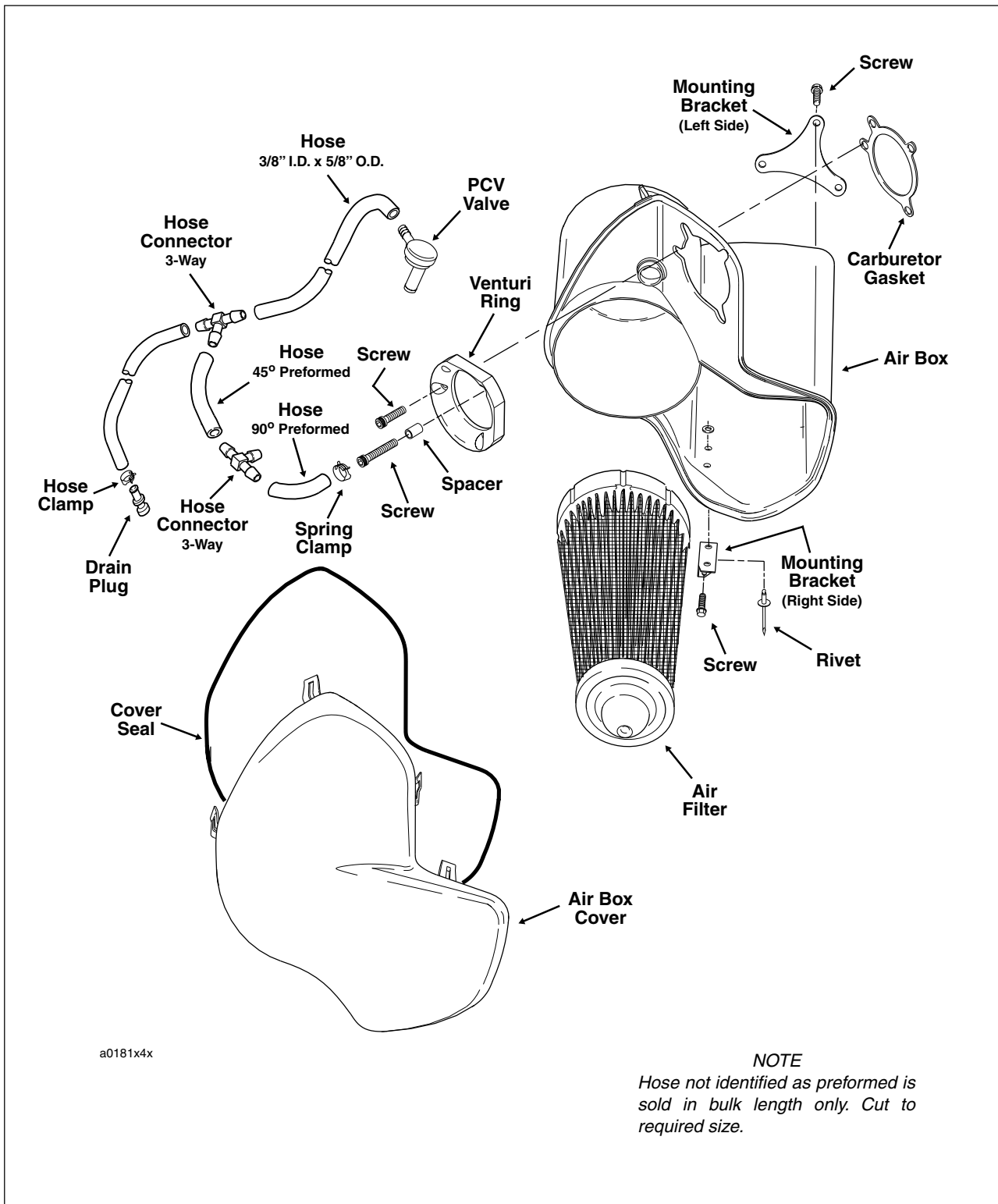

Figure 4-14. Air Cleaner Assembly (Non-California Models)

REMOVAL

1. Remove seat. Depress latch at bottom and pull seat up and back to remove.

WARNING

To protect against shock and accidental start-up of vehicle, disconnect the negative battery cable before proceeding. Inadequate safety precautions could result in death or serious injury.

2. Unthread bolt and remove battery negative cable (black) from battery negative (-) terminal.
3. Moving to left side of vehicle, rotate handle on fuel valve to the fully vertical position to shut the gasoline supply to the carburetor OFF.
4. Remove air cleaner assembly. See [4.3 AIR CLEANER](#), steps 1-10.
5. Locate 6-place Deutsch connector in front of ignition coil and depress external latch to separate pin and socket halves.
6. Turn slotted screw to loosen band clamp on outboard side of manifold-carburetor coupler. Pull carburetor from coupler.

WARNING

Some gasoline will drain from the fuel inlet hose when disconnected from the carburetor. Thoroughly wipe up any spilled fuel immediately. Dispose of rags in a suitable manner. Gasoline is extremely flammable and highly explosive. Inadequate safety precautions could result in death or serious injury.

7. Using a side cutters, cut clamp and remove fuel inlet hose from fitting at side of carburetor.

NOTE

On California models, pull purge hose from fitting on same side of carburetor.

8. Rotate cable adjusters at handlebar to add slack to idle and throttle cables.

WARNING

As the carburetor is removed, be sure to keep assembly upright as the float bowl contains gasoline. Tilting the carburetor or turning it upside down will cause the gasoline to drain onto surrounding area. Gasoline is extremely flammable and highly explosive. Inadequate safety precautions could result in death or serious injury.

9. Loosen allen head screw to remove cable clamp at top of throttle cable bracket. Using a needle nose pliers, carefully pull idle cable barrel from hole in throttle wheel (farthest from cam stop). Pull throttle cable barrel from remaining hole in throttle wheel. Release idle and throttle cables from guides in throttle cable bracket and remove carburetor from vehicle.
10. Keeping carburetor upright, move to bench area. Without tilting carburetor or turning upside down, remove four

Phillips screws at bottom to remove float bowl from carburetor body. Carefully pour gasoline in float bowl into a suitable container. Loosely install screws to fasten float bowl to carburetor body.

11. If carburetor cleaning is required, proceed as follows:
 - a. Using special TORX bit (Snap-on® TTXR20E), remove two tamper-resistant T20 TORX screws to release throttle position sensor from carburetor housing.
 - b. Remove Phillips screw (with lockwasher) to release stay plate on auto-enrichener from carburetor housing. Pull enrichener from carburetor bore.

INSTALLATION

1. If throttle position sensor and auto-enrichener were removed for carburetor cleaning, proceed as follows:
 - a. Align holes in throttle position sensor with those in carburetor housing. Using special TORX bit (Snap-on® TTXR20E), **loosely** install two tamper-resistant T20 TORX screws.
 - b. Carefully insert auto-enrichener into carburetor bore. Install Phillips screw (with lockwasher) to secure stay plate on enrichener to carburetor housing. Tighten screw to 13-23 **in-lbs** (2-3 Nm).
2. If loose, tighten four Phillips screws at bottom to secure float bowl to carburetor body.
3. Slide **new** clamp onto free end of fuel inlet hose. Install hose onto fitting at side of carburetor. Crimp clamp using HOSE CLAMP PLIERS (HD-97087-65B).

NOTE

On California models, push purge hose onto fitting on same side of carburetor.

4. Install sleeve on idle cable housing into longer cable guide on throttle cable bracket. Drawing idle cable downward, fit barrel end into hole in throttle wheel (farthest from cam stop). Install sleeve on throttle cable housing into shorter cable guide inserting barrel end into remaining hole in throttle wheel.

5. Verify that cables are seated in channel of throttle wheel, and using cable adjusters at handlebar, tighten cables as necessary to keep barrel ends from dislodging. Verify operation by turning throttle grip and observing cable action.
6. Position cable clamp at top of cable bracket, so that short end is above longer cable guide, long end above shorter cable guide. With clamp capturing sleeves on cable housings, tighten allen head screw to fix position.
7. Install carburetor onto manifold-carburetor coupler. Turn slotted screw to tighten band clamp on outboard side of coupler.
8. Mate pin and socket halves of 6-place Deutsch connector.
9. Adjust throttle cables. See 2.16 THROTTLE CONTROL.
10. Insert bolt through battery negative cable (black) into threaded hole of battery negative (-) terminal. Tighten bolt to 60-96 in-lbs (7-11 Nm).
11. Adjust throttle position sensor. For instructions, see 4.6 THROTTLE POSITION SENSOR, step 6.
12. Install air cleaner assembly. See 4.3 AIR CLEANER steps 1-12.
13. Position seat on frame backbone, so that tongue at bottom engages slot in frame weldment. Push down on rear of seat until spring-loaded latch fully engages groove of seat pin.

WARNING

Pull up on seat to verify that it is properly secured, front and rear. A loose seat may shift during vehicle operation and startle the rider, possibly causing loss of vehicle control that could result in death or serious injury.

14. Rotate handle of fuel valve to ON and carefully inspect for leaks. Return the valve to the OFF position when finished.
15. Adjust engine idle speed. For instructions, see 1.19 IGNITION TIMING AND IDLE SPEED ADJUSTMENT.

DISASSEMBLY - TOP END

1. Remove gold Phillips screw (with top collar) to free throttle cable bracket from carburetor top. Remove gold Phillips screw (with lockwasher) at side of carburetor to release throttle cable bracket. Set bracket aside.
2. Remove three remaining top screws to release carburetor top from body.
3. Remove vacuum piston spring. Carefully raise diaphragm to remove vacuum piston assembly. Remove spring seat and jet needle from vacuum piston bore. See Figure 4-16.

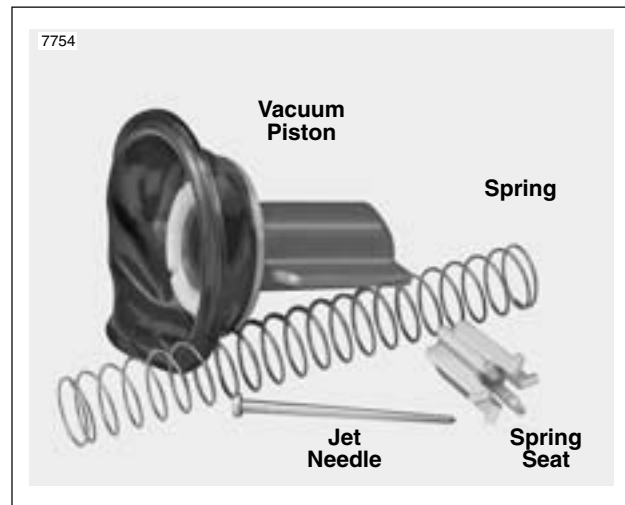

Figure 4-15. Carburetor-Top End

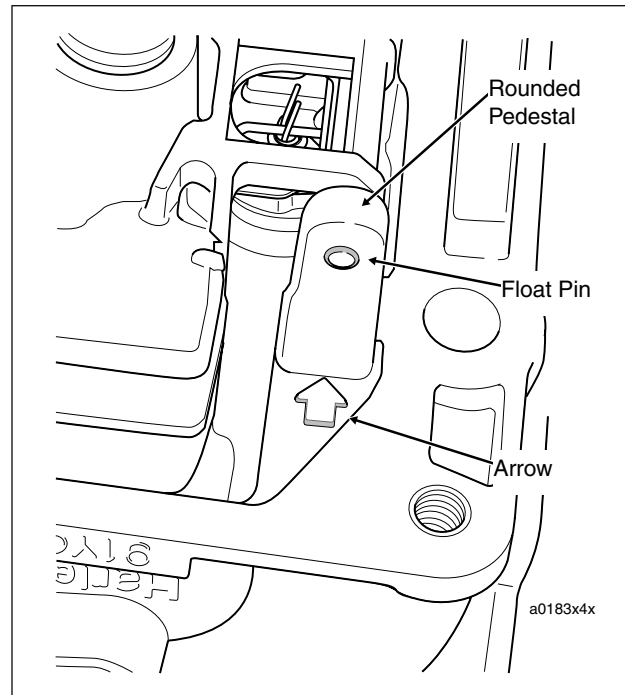

Figure 4-16. Remove Float Pin in Direction of Arrow

DISASSEMBLY - BOTTOM END

1. Turn carburetor upside down and remove four Phillips screws loosely installed at bottom. Remove float bowl from carburetor body.

CAUTION

Tapping the float pin out from the squared pedestal side will result in damage that requires carburetor replacement.

2. Using a small center punch and hammer, carefully tap float pin from holes in pedestals. The rounded pedestal has an interference fit to ensure that the float pin is securely held, so always tap out the pin in the direction of the cast-in arrow (that is, from the interference side). See [Figure 4-16](#).
3. Remove float and fuel valve. Carefully slide clip on fuel valve from tab on float. Remove wireform clip from groove in fuel valve. See upper frame of [Figure 4-18](#).
4. Using slot at top, turn main jet with flat tip screwdriver to unthread from needle jet holder. If necessary, hold hex on needle jet holder with a 5/16 inch wrench to prevent rotation. See [Figure 4-17](#).
5. Using a 5/16 inch wrench, turn hex on needle jet holder to unthread from main jet bore.
6. Turn carburetor right side up to drop out needle jet, which is loose in main jet bore. See middle frame of [Figure 4-18](#).
7. Insert thin bladed flat tip screwdriver into slow jet bore, and using slot at top of slow jet, unthread to remove. See [Figure 4-17](#). and lower frame of [Figure 4-18](#).

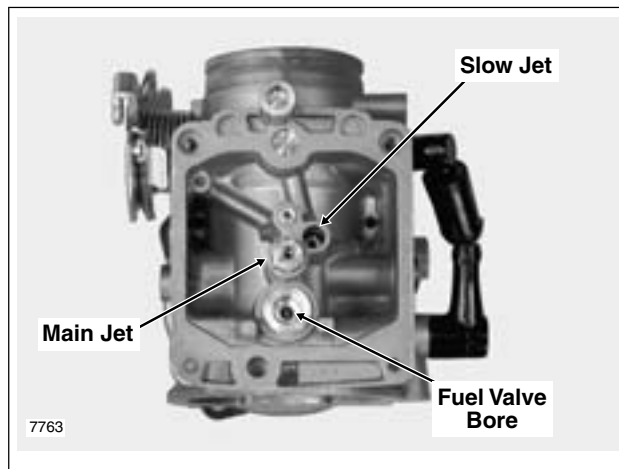

Figure 4-17. Carburetor Housing

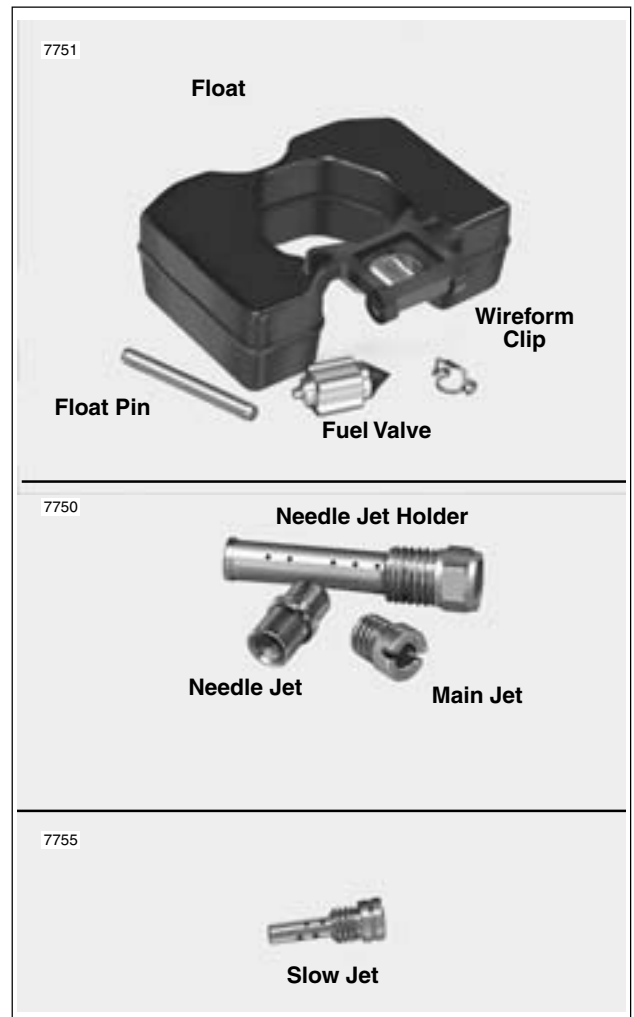

Figure 4-18. Carburetor- Bottom End

CLEANING AND INSPECTION

Carburetor Housing

1. Clean all internal air/fuel passages in carburetor housing with carburetor cleaner. Blow out passages using low pressure compressed air. Proceed as follows:

WARNING

Compressed air can pierce the skin and cause injury. Never use your hand to check for leaks or to determine air flow rates. Wear safety glasses to shield your eyes from flying dirt and debris. Failure to comply could result in death or serious injury.

Slow Speed Circuit

- a. Spray carburetor cleaner into air inlet hole of slow speed circuit. See A of Figure 4-19. While spraying, verify that solution exits slow jet bore at bottom of carburetor housing. See B of Figure 4-19. Placing finger over slow jet bore, verify that solution exits four pin holes just inboard of the throttle plate, as well as the single pin hole outboard of the throttle plate.
- b. Using a tapered, rubber-tipped nozzle on the air hose (to prevent both loss of air pressure and to avoid scratching or nicking the bore), apply low pressure compressed air into air inlet hole to blow carburetor cleaner out of slow jet bore. Placing gloved finger over slow jet bore, blow carburetor cleaner out of pin holes inboard and outboard of throttle plate.

Main Circuit

- a. Plugging main jet hole in carburetor throat, spray carburetor cleaner into air inlet hole of main circuit. See A of Figure 4-19. While spraying, verify that solution exits main jet bore at bottom of carburetor housing. See B of Figure 4-19.
- b. Using a tapered, rubber-tipped nozzle on the air hose (to prevent both loss of air pressure and to avoid scratching or nicking the bore), apply low pressure compressed air into air inlet hole to blow carburetor cleaner out of hole in carburetor throat. Placing gloved finger over hole in carburetor throat, blow carburetor cleaner out of main jet bore at bottom of carburetor housing.

Float Bowl Vent

- a. Spray carburetor cleaner into air inlet hole of float bowl vent. See A of Figure 4-19. While spraying, verify that solution exits two holes in float bowl chamber at bottom of carburetor housing. See B of Figure 4-19.
- b. Using a tapered, rubber-tipped nozzle on the air hose (to prevent both loss of air pressure and to avoid scratching or nicking the bore), apply low pressure compressed air into air inlet hole of float bowl vent to blow carburetor cleaner out of holes in float bowl chamber.

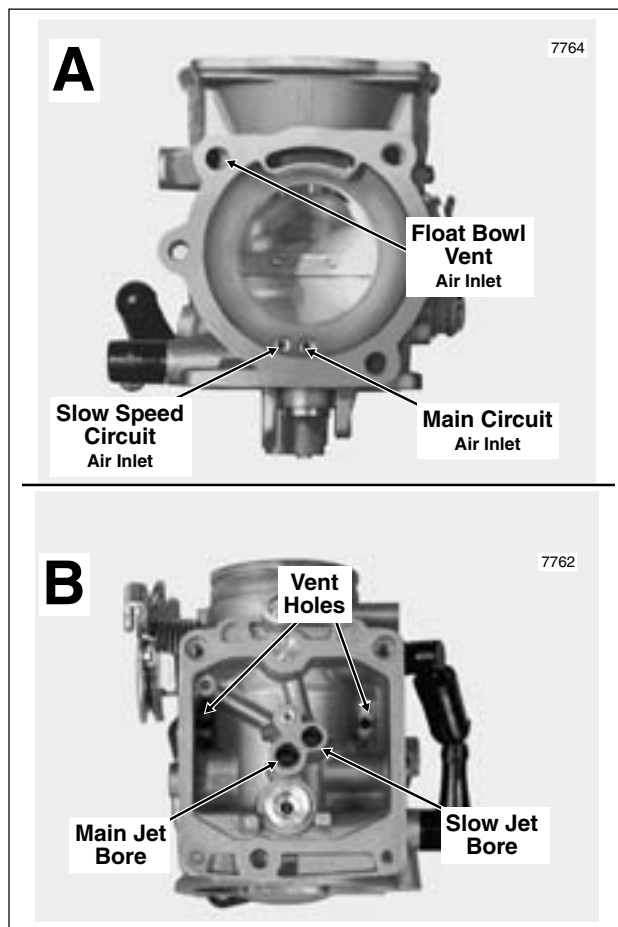

Figure 4-19. Clean Air/Fuel Passages in Carburetor

Top End Components

1. Thoroughly clean all loose parts (except diaphragm) with carburetor cleaner. See Figure 4-15. Blow dry using low pressure compressed air.

WARNING

Compressed air can pierce the skin and cause injury. Never use your hand to check for leaks or to determine air flow rates. Wear safety glasses to shield your eyes from flying dirt and debris. Failure to comply could result in death or serious injury.

2. Inspect parts as follows:
 - a. Hold vacuum piston up to strong light source. Examine diaphragm for pin holes, cuts, tears or pinching. Replace if any damage is found.
 - b. Examine passage at bottom of vacuum piston bore. Verify that passage is clean and open.
 - c. Examine vacuum piston spring for stretching, crimping, distortion or other damage. Inspect spring seat for cracks. Replace parts if necessary.
 - d. Examine slides at sides of vacuum piston to verify that surfaces are clean and smooth. Clean or buff out any rough surfaces.
 - e. Examine tip of jet needle for grooves or scratches. Needle should be completely straight, while surface condition at taper should be smooth and even. Replace needle if necessary.

Bottom End Components

1. Thoroughly clean all loose parts with carburetor cleaner. See [Figure 4-18](#). Blow dry using low pressure compressed air.

WARNING

Compressed air can pierce the skin and cause injury. Never use your hand to check for leaks or to determine air flow rates. Wear safety glasses to shield your eyes from flying dirt and debris. Failure to comply could result in death or serious injury.

2. Inspect parts as follows:
 - a. Inspect O-ring in groove of float bowl for cuts, tears or signs of deterioration. Replace O-ring if distorted or if sealing surface is damaged.
 - b. Inspect float pin for damage or distortion. Replace float pin if corroded, nicked or bent.
 - c. Clean float and inspect for cracks or other damage. Submerge float in a glass of water. Replace float if not water tight.
 - d. Depress pin on fuel valve to verify that it returns to the full-out position. Thoroughly clean valve with carburetor cleaner if pin is dirty or sticks. Inspect rubber cone on valve for dirt, cracks, hardening or wear. Inspect wireform clip for distortion. Replace fuel valve assembly if any of these conditions are found.
 - e. Inspect fuel valve seat in carburetor housing for dirt, damage or corrosion. Replace carburetor if seat damage or corrosion is present.
 - f. Verify cleanliness of slow jet. Be sure that all orifices are clean and open. Replace jet if damaged.

Verify cleanliness of main jet, needle jet holder and needle jet. Verify that orifices in needle jet holder are clean and open. Replace parts if damaged.

ASSEMBLY - TOP END

1. Install vacuum piston into carburetor body. Slides on piston are offset, so piston will fit into slide track groove only one way. If vacuum piston does not fit, rotate assembly 180°.
2. Insert jet needle into vacuum piston bore, so that it enters center hole at bottom. In the installed position, head of needle contacts boss at bottom of vacuum piston bore, while length of shaft resides in main jet bore.
3. With the legged side down, slide spring seat over top of needle in vacuum piston bore. Slide spring over spring seat.
4. Verify that lip on edge of diaphragm is seated in groove of carburetor flange.

NOTE

Diaphragm expands when in contact with fuel. If diaphragm is difficult to seat in groove because of this condition, allow diaphragm to dry before attempting to install.

5. Fit free end of spring over boss on inboard side of carburetor top, and keeping spring straight, align holes in top with those in flange.
6. Holding top to flange, check for proper diaphragm seal by pushing up on vacuum piston (from intake side) and releasing. If diaphragm is sealed correctly, very slight resistance should be felt when pushing up, and piston should be slow to extend. If piston movement is restricted, spring is cocked. Lift up on top and then lower carefully keeping spring coils straight.
7. Install three black top screws in holes furthest from throttle wheel. Alternately tighten screws until snug.
8. Slide gold top collar into remaining hole in carburetor top. With end of idle screw resting on top of throttle cam stop, align holes in throttle cable bracket with those in carburetor body and top cover. To prevent bending bracket or throttle cam, first install gold Phillips screw (with lock-washer) at side of carburetor. At carburetor top, install remaining Phillips screw.

ASSEMBLY - BOTTOM END

1. Insert slow jet into slow jet bore. See [Figure 4-18](#). Insert thin bladed flat tip screwdriver into bore, and using slot at top of slow jet, tighten until snug.
2. Place needle jet into main jet bore. See [Figure 4-18](#). Be sure end with chamfered edge and larger ID goes in first.
3. Insert needle jet holder into main jet bore, and using a 5/16 inch wrench, turn hex until snug.
4. Thread main jet into needle jet holder. Using slot at top of main jet, tighten with flat tip screwdriver until snug.
5. Install wireform clip into groove on pin side of fuel valve, if removed. Using wireform clip, carefully hang fuel valve onto tab of float, so that tip of rubber cone hangs flush with top of float (the top being the side opposite the pivot arm).
6. Place float into cavity of carburetor inserting fuel valve into bore between pedestals. See [Figure 4-17](#).

CAUTION

Tapping the float pin in from the rounded pedestal side will result in damage that requires carburetor replacement.

7. Insert float pin through squared pedestal and pivot arm of float into rounded pedestal. Since the rounded pedestal has an interference fit to ensure that the float pin is securely held, always install pin from the loose side (in the direction opposite the cast-in arrow). Using a small center punch and hammer, carefully tap float pin until ends are flush with outboard sides of pedestals.
8. Perform float level check as follows:
 - a. Place carburetor on a clean flat surface with the intake manifold side down. See A of [Figure 4-20](#).
 - b. Tilt the carburetor 15° to 20° in a counter-clockwise direction until float comes to rest. See B of [Figure 4-20](#).

NOTE

The measurements will be incorrect if the carburetor is tilted less than 15° or more than 20° .

- c. Using a dial vernier caliper or dial caliper depth gauge, measure the distance from the face of the carburetor flange to the outboard edge of the float. Be careful not to push on float while measuring.
 - d. If the measurement is between 0.413 inch and 0.453 inch (10.49 - 11.51 mm), then the float level is within specification. Proceed to step 9.
 - e. If the float level is not within specification, remove the float, and referencing the table below, carefully bend the tab slightly to adjust the float level. For example, to increase the float measurement, bend the tab toward the carburetor body. This will have the affect of decreasing the amount of gas in the float bowl after assembly.
 - f. Install float and check float level again. Repeat procedure as necessary until float level is within specification.
9. Install new O-ring into groove of float bowl, if removed. Be sure to thoroughly clean groove before O-ring installation.

10. Install four Phillips screws to secure float bowl at bottom of carburetor body. Tighten screws until snug.

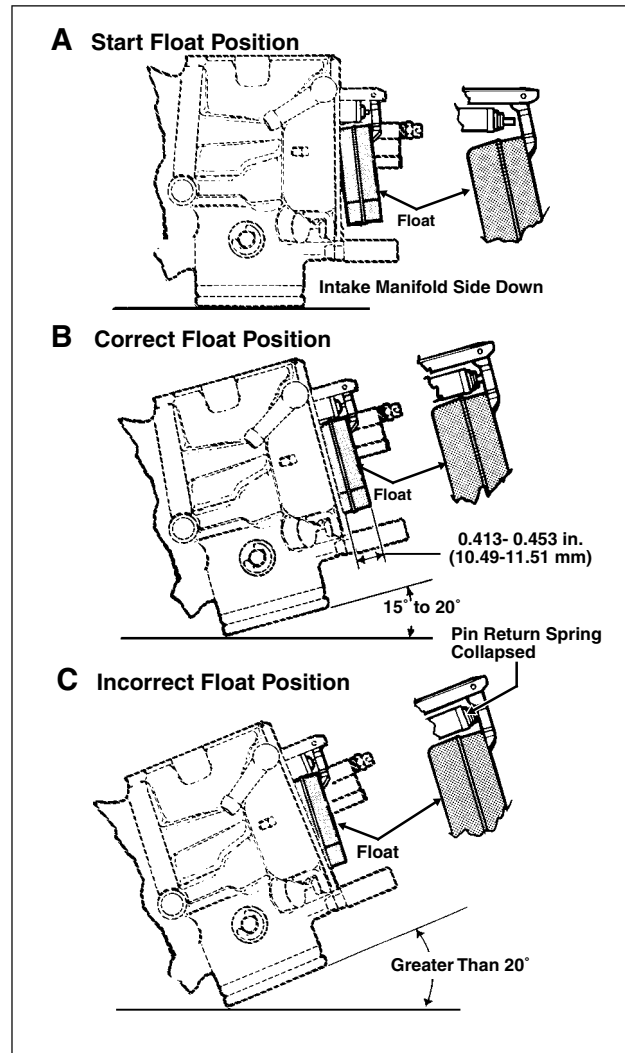

Figure 4-20. Float Check and Adjustment

Float Level Tab		
Float Measurement	Bend Tab	Amount of Gas in Float Bowl
To Increase	Toward Carburetor Body	Decreased
To Decrease	Away From Carburetor Body	Increased

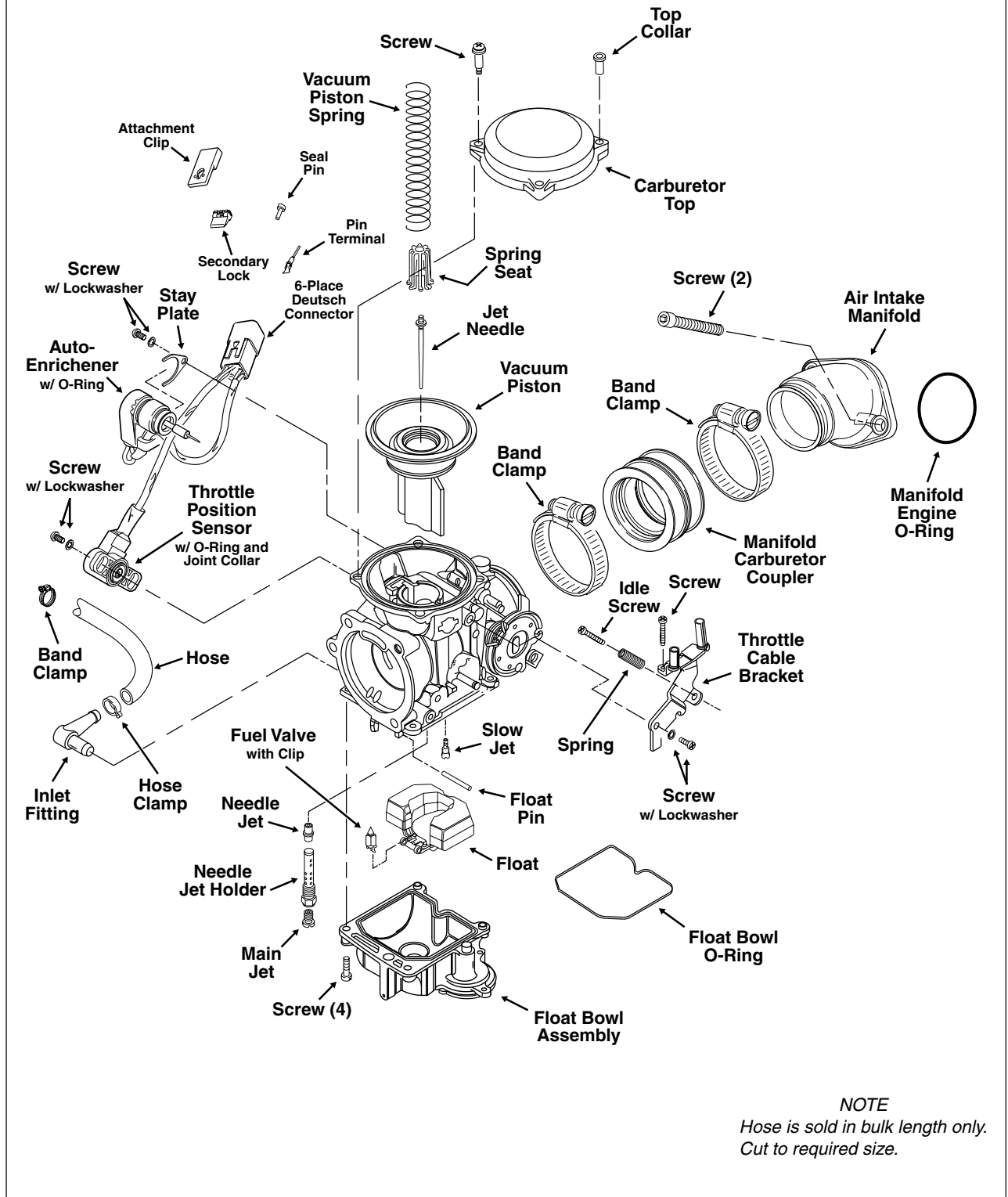

Figure 4-21. Carburetor Assembly

REMOVAL

NOTE

For electrical diagnostics and troubleshooting, please refer to 7.7 AUTO ENRICHENER.

1. Remove seat. Depress latch at bottom and pull seat up and back to remove.

WARNING

To protect against shock and accidental start-up of vehicle, disconnect the negative battery cable before proceeding. Inadequate safety precautions could result in death or serious injury.

2. Unthread bolt and remove battery negative cable (black) from battery negative (-) terminal.
3. Release five latches around perimeter of air box cover.
4. Remove single Phillips screw at bottom of air box cover (7 o'clock position).
5. Pull cover from air box.
6. Remove hex screw at bottom of air box (6 o'clock position) to release bracket from crankcase hole.
7. Moving to left side of vehicle, remove top two flange bolts from triangular shaped bracket fastened to crankcase. Do not remove bottom bolt to crankcase.

CAUTION

Do not take bolt in and out of the crankcase unless necessary. Since the potential for stripping always exists during removal and installation, leave the bolt intact to avoid possible damage to the crankcase.

8. Returning to the right side of the vehicle, turn slotted screw to loosen band clamp on outboard side of manifold-carburetor coupler. Pull carburetor from coupler.
9. Carefully pull air box out of opening. When partially removed, detach PCV outlet hose from middle fitting on 3-way connector.
10. Locate 6-place Deutsch connector in front of ignition coil and depress external latch to separate pin and socket halves. Remove pin terminals from chambers 1 and 2.

NOTE

For instructions on properly removing wire terminals, see Appendix B.

11. Remove Phillips screw (with lockwasher) to release stay plate on auto-enrichener from carburetor housing. Pull enrichener from carburetor bore.

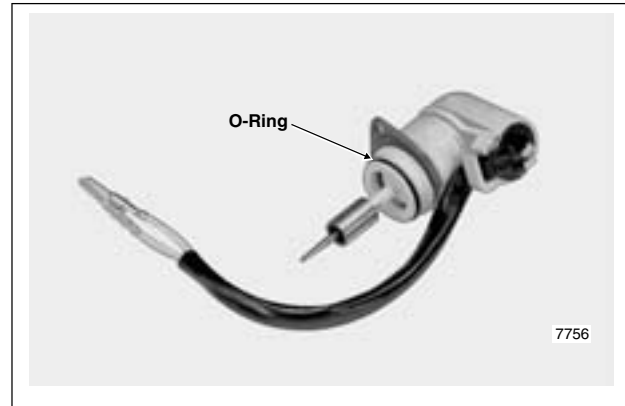

Figure 4-22. Auto-Enrichener

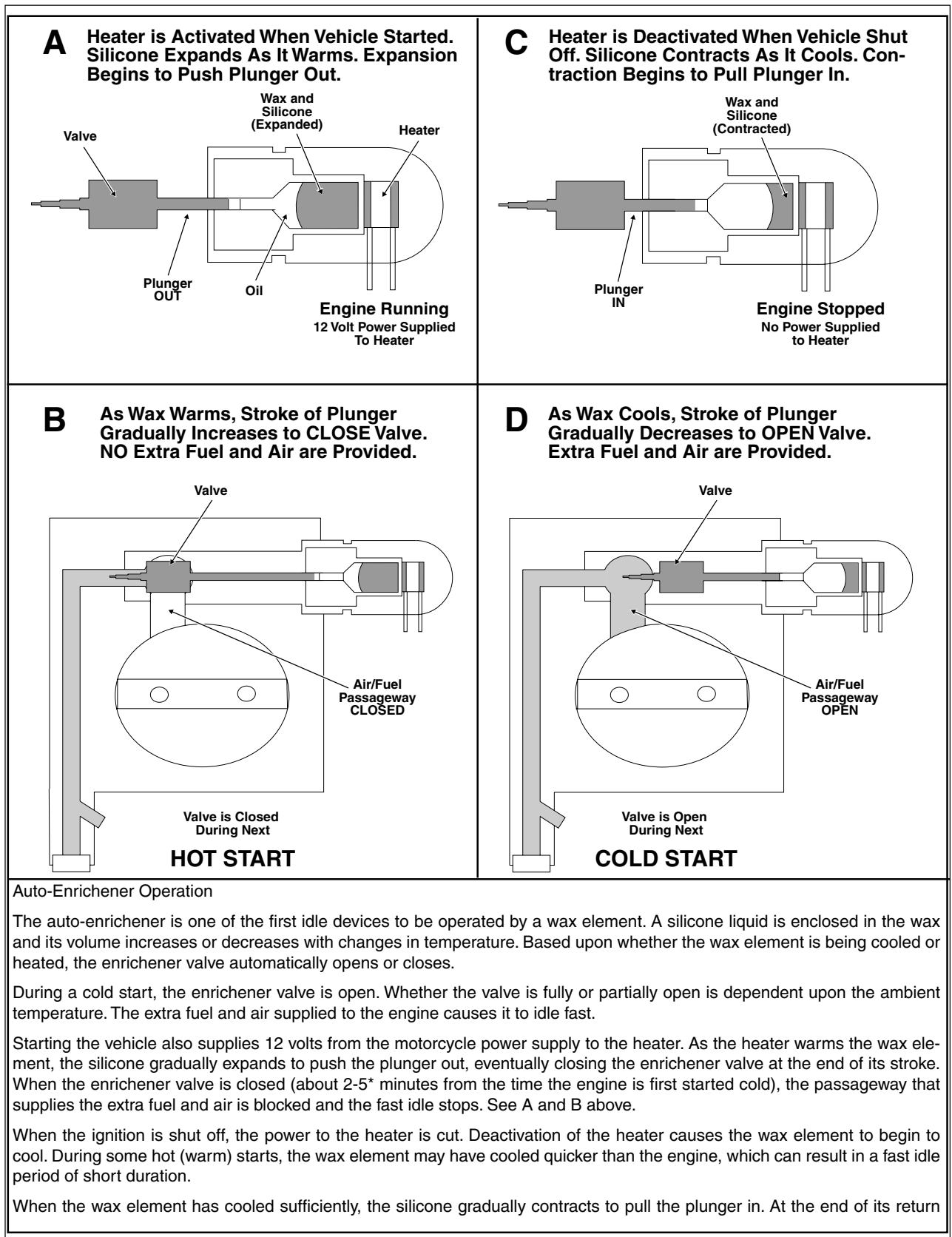

Figure 4-23. Auto-Enrichener

INSTALLATION

1. Obtain **new** auto-enrichener assembly. If old enrichener is used, inspect O-ring for cuts, tears or signs of deterioration. Replace O-ring if necessary. See Figure 4-22.
2. Carefully insert auto-enrichener into carburetor bore. Install Phillips screw (with lockwasher) to secure stay plate on enrichener to carburetor housing. Tighten screw to 13-23 **in-lbs** (2-3 Nm).
3. Locate 6-place Deutsch connector and install pin terminals in chambers 1 and 2. Mate pin and socket halves of connector.

NOTE

For instructions on properly installing wire terminals, see Appendix B.

4. Standing on the right side of the vehicle, start air box into opening. When partially installed, push PCV outlet hose onto middle fitting of 3-way connector, and loosely install carburetor onto manifold-carburetor coupler.
5. Moving to opposite side of vehicle, apply a small dab of Loctite Low Strength Threadlocker 222 (Purple) to threads of two flange bolts. Slide bolts through top two holes of triangular bracket and install into left side of air box. Alternately tighten screws to 3-5 ft-lbs (4-7 Nm).
6. Returning to the right side of the vehicle, fix position of carburetor on manifold-carburetor coupler. Turn slotted screw to tighten band clamp on outboard side of coupler.
7. Apply one drop of Loctite High Strength Threadlocker 262 (red) to threads of hex screw. Install screw at bottom of air box (6 o'clock position) to secure air box bracket to crankcase hole. Tighten screw to 10-12 ft-lbs (14-16 Nm).
8. Taking note of index pin on inboard side of cover and small depression at tip of cone, position cover onto air box so that pin engages depression.
9. Lock five latches around perimeter of air box cover.
10. Install Phillips screw at bottom of air box cover (7 o'clock position) to secure cover to air box. Tighten screw to 4-6 **in-lbs** (0.5-0.7 Nm).
11. Insert bolt through battery negative cable (black) into threaded hole of battery negative (-) terminal. Tighten bolt to 60-96 **in-lbs** (7-11 Nm).
12. Position seat on frame backbone, so that tongue at bottom engages slot in frame weldment. Push down on rear of seat until spring-loaded latch fully engages groove of seat pin.

WARNING

Pull up on seat to verify that it is properly secured, front and rear. A loose seat may shift during vehicle operation and startle the rider, possibly causing loss of vehicle control that could result in death or serious injury.

REMOVAL

NOTE

For electrical diagnostics and troubleshooting, please refer to 7.4 THROTTLE POSITION SENSOR (TP Sensor).

1. Remove seat. Depress latch at bottom and pull seat up and back to remove.

WARNING

To protect against shock and accidental start-up of vehicle, disconnect the negative battery cable before proceeding. Inadequate safety precautions could result in death or serious injury.

2. Unthread bolt and remove battery negative cable (black) from battery negative (-) terminal.
3. Release five latches around perimeter of air box cover.
4. Remove single Phillips screw at bottom of air box cover (7 o'clock position).
5. Pull cover from air box.
6. Remove hex screw at bottom of air box (6 o'clock position) to release bracket from crankcase hole.
7. Moving to left side of vehicle, remove top two flange bolts from triangular shaped bracket fastened to crankcase. Do not remove bottom bolt to crankcase.

CAUTION

Do not take bolt in and out of the crankcase unless necessary. Since the potential for stripping always exists during removal and installation, leave the bolt intact to avoid possible damage to the crankcase.

8. Returning to the right side of the vehicle, turn slotted screw to loosen band clamp on outboard side of manifold-carburetor coupler. Pull carburetor from coupler.
9. Carefully pull air box out of opening. When partially removed, detach PCV outlet hose from middle fitting on 3-way connector.
10. Locate 6-place Deutsch connector in front of ignition coil and depress external latch to separate pin and socket halves. Remove pin terminals from chambers 3 through 5.

NOTE

For instructions on properly removing wire terminals, see SECTION 7, ELECTRICAL, DEUTSCH ELECTRICAL CONNECTORS.

11. Using special TORX bit (Snap-on® TTXR20E), remove two tamper-resistant T20 TORX screws to release throttle position sensor from carburetor. Pull sensor from carburetor bore.

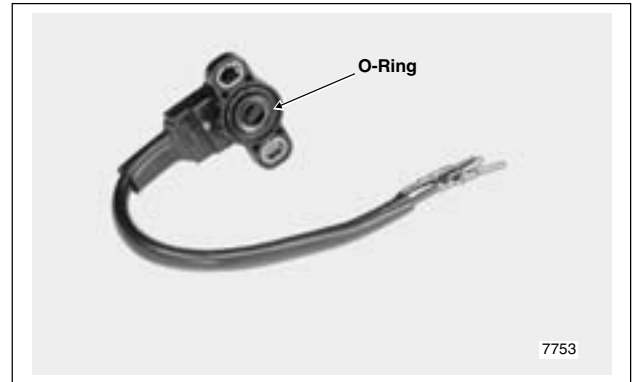

Figure 4-24. Throttle Position Sensor

INSTALLATION

1. Obtain **new** throttle position sensor. If old sensor is used, inspect O-ring for cuts, tears or signs of deterioration. Replace O-ring if necessary. See [Figure 4-24](#).
2. Align holes in throttle position sensor with those in carburetor housing. Using special TORX bit (Snap-on® TTXR20E), **loosely** install two tamper-resistant T20 TORX screws.

NOTE

The tamper-resistant screws are not to be tightened until the throttle position sensor has been properly adjusted. See the instructions under step 6 for details.

3. Locate 6-place Deutsch connector and install pin terminals in chambers 3 through 5. Mate pin and socket halves of connector.

Throttle Position Sensor Connector		
Chamber Number	Wire Color	Function
3	Light Blue	Output
4	Yellow	Input
5	Black	Ground

NOTE

For instructions on properly installing wire terminals, see [Appendix B](#).

4. Insert bolt through battery negative cable (black) into threaded hole of battery negative (-) terminal. Tighten bolt to 60-96 **in-lbs** (7-11 Nm).
5. Standing on the right side of the vehicle, start air box into opening. When partially installed, push PCV outlet hose onto middle fitting of 3-way connector, and loosely install carburetor onto manifold-carburetor coupler.
6. Adjust throttle position sensor as follows:
 - a. Back off idle adjustment screw so throttle plate is fully closed.
 - b. Completely open and close the throttle by rotating the throttle control through its full range of motion.
 - c. Using special TORX bit (Snap-on® TTXR20E), loosen the two tamper-resistant T20 TORX screws just enough to allow sensor to rotate.
 - d. Disconnect pin 3 in connector [88B] (main wire harness).
 - e. Install Breakout Box Adaptors (HD-42962) and Breakout Box (HD-42682) using black connectors between connector halves [88A] and [88B].
 - f. Turn ignition switch to ON. Using a multimeter, measure voltage between pin 3 (V/W) and pin 5 (BK).
 - g. Adjust (rotate) throttle position sensor (TPS) until voltage reading is 0.5V +/- 0.05V.
 - h. Completely open and close the throttle by rotating the throttle control through its full range of motion. Wide Open Throttle (WOT) should not exceed 3.7V and reading should increase consistently as throttle is opened. If the voltage reading is erratic or the voltage reading at WOT exceeds 3.7V see [Figure 7-10](#) for diagnostic testing.

NOTE

After WOT, the TPS reading may not return back to exactly 0.5V +/- 0.05V. To re-check exact TPS voltage reading, turn cycle key off and on.

- i. Tighten TP Sensor mounting screws to 13-23 **in-lbs** (2-3 Nm).
7. Moving to opposite side of vehicle, apply a small dab of Loctite Low Strength Threadlocker 222 (Purple) to threads of two flange bolts. Slide bolts through top two holes of triangular bracket and install into left side of air box. Alternately tighten screws to 3-5 ft-lbs (4-7 Nm).
 8. Returning to the right side of the vehicle, fix position of carburetor on manifold-carburetor coupler. Turn slotted screw to tighten band clamp on outboard side of coupler.
 9. Apply one drop of Loctite High Strength Threadlocker 262 (red) to threads of hex screw. Install screw at bottom of air box (6 o'clock position) to secure air box bracket to crankcase hole. Tighten screw to 10-12 ft-lbs (14-16 Nm).
 10. Taking note of index pin on inboard side of cover and small depression at tip of cone, position cover onto air box so that pin engages depression.
 11. Lock five latches around perimeter of air box cover.
 12. Install Phillips screw at bottom of air box cover (7 o'clock position) to secure cover to air box. Tighten screw to 4-6 **in-lbs** (0.5-0.7 Nm).
 13. Position seat on frame backbone, so that tongue at bottom engages slot in frame weldment. Push down on rear of seat until spring-loaded latch fully engages groove of seat pin.

WARNING

Pull up on seat to verify that it is properly secured, front and rear. A loose seat may shift during vehicle operation and startle the rider, possibly causing loss of vehicle control that could result in death or serious injury.

14. Adjust engine idle speed, as follows:

NOTE

Be sure the engine is warmed up to normal operating temperature **BEFORE** adjusting engine idle speed.

- a. With the engine at normal operating temperature (auto-enrichener valve closed), adjust the throttle stop screw so the engine idles at 1200 rpm.

NOTE

To measure engine rpm, use a hand held inductive tachometer (Snap-on® ONO-SE-1100) to pick up the signal off the spark plug cable.

GENERAL

Buell motorcycles sold in the state of California are equipped with an evaporative (EVAP) emissions control system. In conformance with California Air Resource Board (CARB) regulations, the EVAP system prevents both fuel and crankcase vapors from escaping into the atmosphere. See [Figure 4-25](#).

The EVAP system functions as follows:

- The fuel vapor **vent tube** connected to the fitting at the front of the fuel cap flange allows fuel vapors in the fuel tank to be vented through the rollover valve to the charcoal canister. If the vehicle is tipped, the rollover valve also prevents the loss of gasoline through the vent tube.
- When the engine is running, negative pressure (vacuum) created at the carburetor venturi draws the fuel vapors stored in the charcoal canister through the **purge hose** to the carburetor where they are burned as part of the normal combustion process.
- Fuel vapors emanating from the carburetor throat are drawn to the charcoal canister through a fitting on the **PCV outlet hose**. A preformed hose on one end of the

fitting is fixed to an allen head screw on the venturi ring for positive location.

- Crankcase vapors passing through the PCV valve follow the fuel vapors to the charcoal canister via a 3-way fitting plumbed into the PCV outlet hose. The fuel and crankcase vapors, after passing through the charcoal canister, travel through the purge hose to the carburetor, and like the vapors from the fuel tank, are burned during combustion.

⚠ WARNING

Verify that the vent tubes and hoses do not contact hot exhaust or engine parts. Tubes contain flammable vapors that can be ignited if damaged, possibly causing fire or explosion, which could result in death or serious injury.

NOTE

The EVAP system has been designed to operate with a minimum of maintenance. Check that all hoses are correctly routed and properly connected. Also, verify that the hoses are not pinched or kinked.

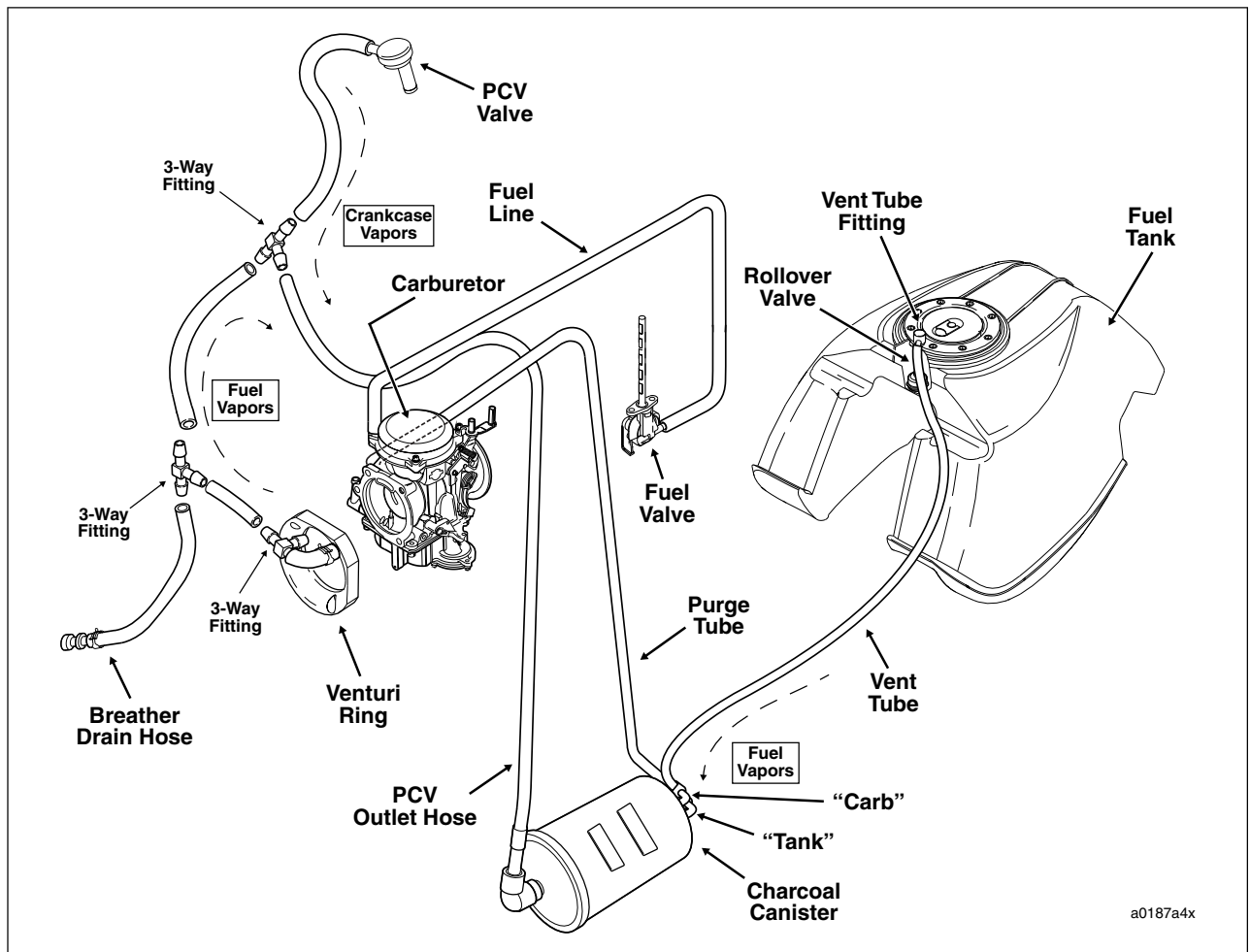

Figure 4-25. California Evaporative Emissions Control System Schematic

CHARCOAL CANISTER

NOTE

On 49 State models, the charcoal canister is absent and the fuel vapor vent tube is vented to the atmosphere.

Removal

1. Remove seat. Depress latch at bottom and pull seat up and back to remove.

WARNING

Always disconnect the negative battery cable first. If the positive cable should contact ground with the negative cable installed, the resulting sparks may cause a battery explosion which could result in death or serious injury.

2. Unthread bolt and remove battery negative cable (black) from battery negative (-) terminal.
3. Standing on left side of vehicle, pull two vent tubes from fittings at the back of the charcoal canister. For correct assembly, mark tubes to correlate with stamps on canister. Mark one tube "CARB" and the other "TANK."
4. Pull PCV outlet hose (connection from carburetor throat and PCV valve) from fitting at front of charcoal canister.
5. Slide charcoal canister rearward until backside of tongue at top of canister just contacts two legs on bracket. Holding canister in position, use the tip of a large screwdriver to push up on outboard leg until it comes down to rest on

top of tongue. See Figure 4-27. Repeat procedure to release leg on inboard side of bracket.

6. Slide charcoal canister toward rear of vehicle until tongue at top of canister is completely free of grooves in bracket.

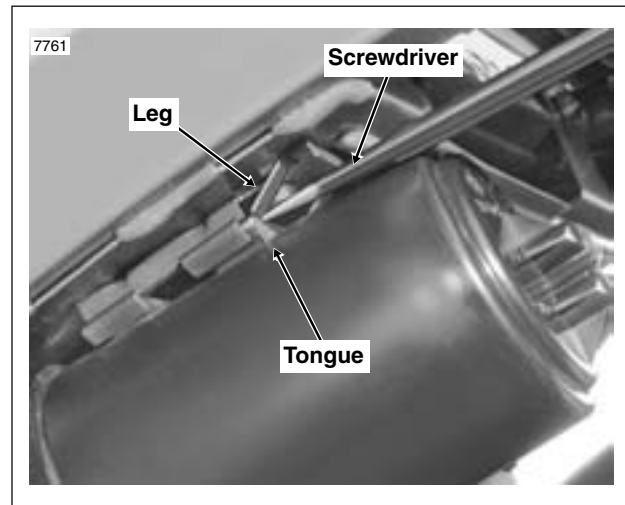

Figure 4-26. Push Up On Legs Of Bracket to Release Charcoal Canister

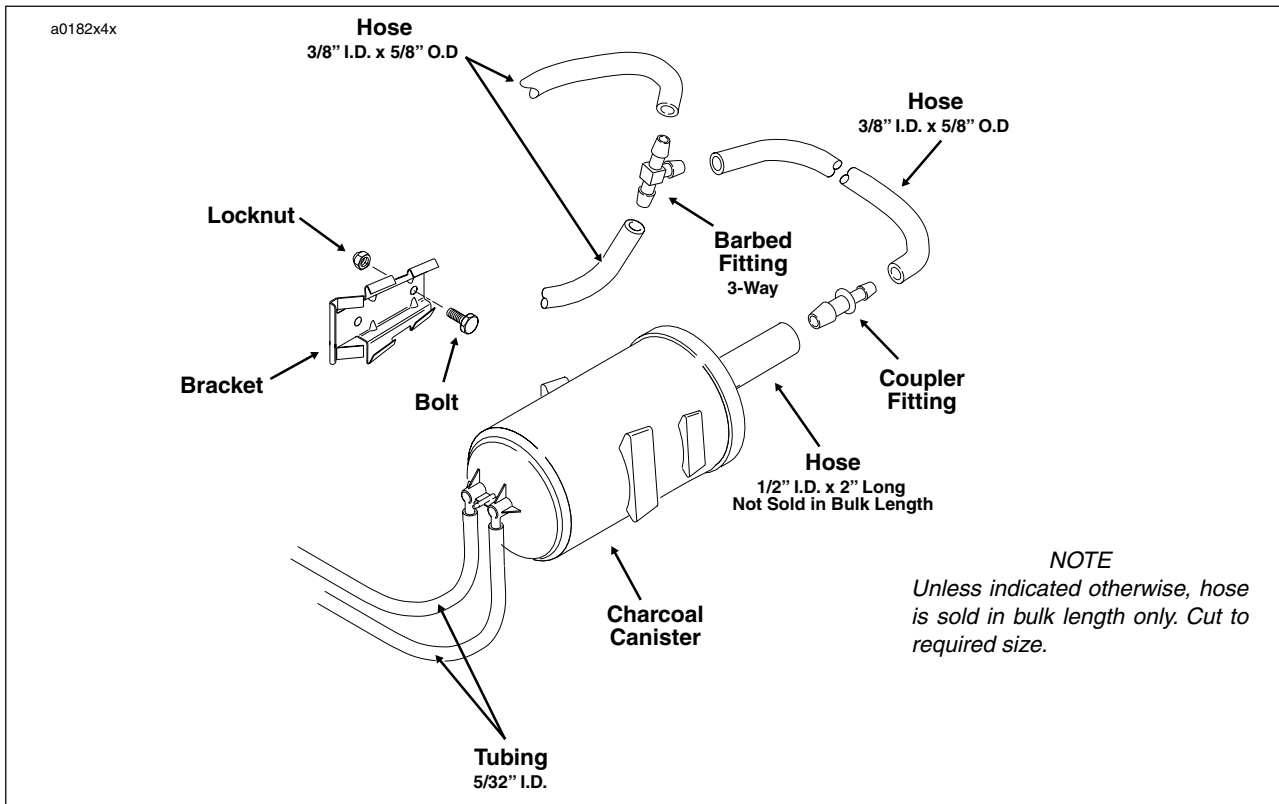

Figure 4-27. Charcoal Canister Assembly

Installation

1. With the vent tube fittings at the rear and pointing inboard, start tongue at top charcoal canister into grooves of bracket.
2. Push charcoal canister toward front of vehicle until legs on bracket snap down to engage back of tongue.
3. Attach vent tubes to fittings at back of charcoal canister. For correct assembly, tubes should have been marked to correlate with stamps on canister, that is, either "CARB" or "TANK."
4. Attach PCV outlet hose (connection from carburetor throat and PCV valve) to fitting at front of charcoal canister.

WARNING

Verify that the vent tubes and hoses do not contact hot exhaust or engine parts. Tubes contain flammable vapors that can be ignited if damaged, possibly causing fire or explosion, which could result in death or serious injury.

5. Recheck vent tube routing to be sure that hoses are not pinched or kinked.
6. Insert bolt through battery negative cable (black) into threaded hole of battery negative (-) terminal. Tighten bolt to 60-96 in-lbs (7-11 Nm).
7. Position seat on frame backbone, so that tongue at bottom engages slot in frame weldment. Push down on rear of seat until spring-loaded latch fully engages groove of seat pin.

WARNING

Pull up on seat to verify that it is properly secured, front and rear. A loose seat may shift during vehicle operation and startle the rider, possibly causing loss of vehicle control that could result in death or serious injury.

ROLLOVER VALVE

See 4.2 FUEL TANK COVER/FUEL TANK.

HOSE ROUTING

Crankcase Breather/Drain/PCV Outlet Hose

Crankcase Breather Hose: The crankcase breather hose runs forward from the PCV valve at the top of the rocker cover through a cable strap loosely installed in two lateral holes in the front engine mounting bracket (just rear of the steering head). After passing through the cable strap, the hose loops rearward following the bottom left side of the frame backbone, where it is captured in yet another cable strap loosely installed around the middle of the backbone (the second of three equally spaced cable straps moving front to rear). Continuing rearward, the hose passes toward the right side of the vehicle just in front of the ignition coil where it mates with a 3-way connector positioned inboard of the carburetor.

First 3-Way Connector: The 3-way connector inboard of the carburetor splits the path of the hose into two directions. The center barb, pointed at the left side of the vehicle, is attached to the hose routed to the charcoal canister, while the end barb is connected to a short hose that jumps to a second 3-

way connector located inboard of the air box.

Charcoal Canister Hose: The hose to the charcoal canister is routed from the center barb on the first 3-way connector back to the left side of the vehicle just behind the ignition coil, and then downward following the rearward arc created by the rounded top of the air box. The hose then runs over the top rear corner of the inner primary housing and enters the loop formed by the hose connected to the oil drain/return fitting at the left side of the frame backbone. Passing through this loop, the hose enters an opening at the front of the passenger foot peg support where it is then connected to the fitting at the front of the charcoal canister.

Second Three-Way Connector: The second 3-way connector inboard of the air box splits the path of the hose once again. The center barb, pointed at the right side of the vehicle, is connected to a hose that runs through a hole in the air box, where it mates with a third and final 3-way connector. The hose on the end barb of the third 3-way connector is clamped to the gold allen head screw on the venturi ring (so that the center barb is positioned at the carburetor throat).

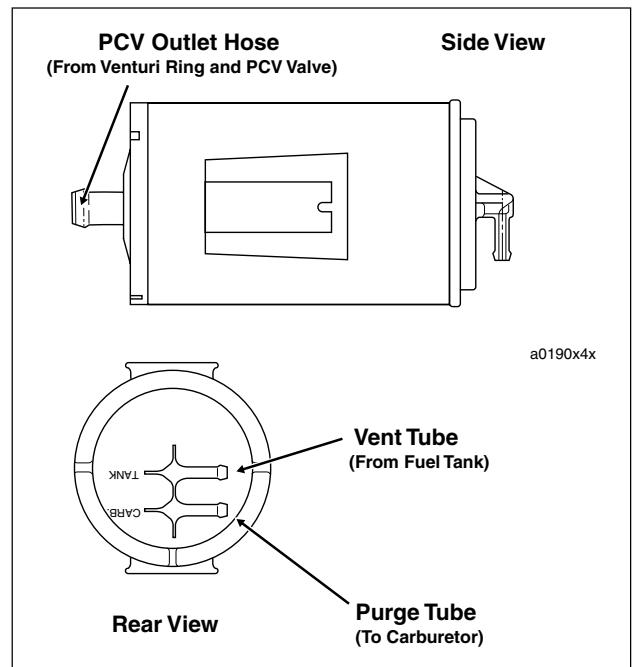

Figure 4-28. Charcoal Canister

Crankcase Breather Drain Hose: The end barb of the second 3-way connector routes the hose to the right side of the vehicle between the top of the air box and the bottom of the frame backbone, where it runs rearward following the bottom right side of the frame backbone. The hose then cuts back to the left side of the vehicle through the opening formed by the frame and the rear of the air box (just above the electric starter). After returning to the left side, the hose passes through the loop formed by the hose connected to the oil drain/return fitting. The hose enters an opening at the front of the passenger foot peg support where it is then clamped along the inboard side above the oil drain hose.

Vent Tube

The vent tube, which is cable strapped to the nozzle of the vent tube fitting at the front of the fuel cap flange, runs downward on the left side of the fuel tank and turns rearward pass-

ing through a cable strap loosely installed around the front of the frame backbone (the first of three equally spaced cable straps moving front to rear). From this point, the vent tube follows the main harness through a large hole in the front engine mounting bracket (just rear of the two lateral holes described earlier). Continuing rearward, the tube follows the bottom left side of the frame backbone running inboard of the crankcase breather hose. Moving outboard of the breather

hose just in front of the ignition coil, the tube follows the ignition module conduit down the left side of the frame backbone and passes through the loop formed by the hose connected to the oil drain/return fitting. The tube enters an opening at the front of the passenger foot peg support where it runs rearward to connect to the upper fitting at the back of the charcoal canister. One cable strap is used to connect the “carb” and “tank” vent tubes together at the back of the canister, while another secures both tubes to the PCV outlet hose at the front of the canister.

NOTE

On non-California models, the end of the “tank” vent tube gets routed through the slot at the front of the tail section and then into the cavity on the inboard side of the battery box (alongside the transmission vent hose), while the “carb” vent tube (purge tube) is absent.

Purge Tube

The purge tube is connected to a fitting on the inboard side of the carburetor, where it passes to the right side of the vehicle just behind the ignition coil. From this point, the tube runs rearward following the same path as the hose to charcoal canister (front fitting), except that it is connected to the lower fitting at the back of the canister.

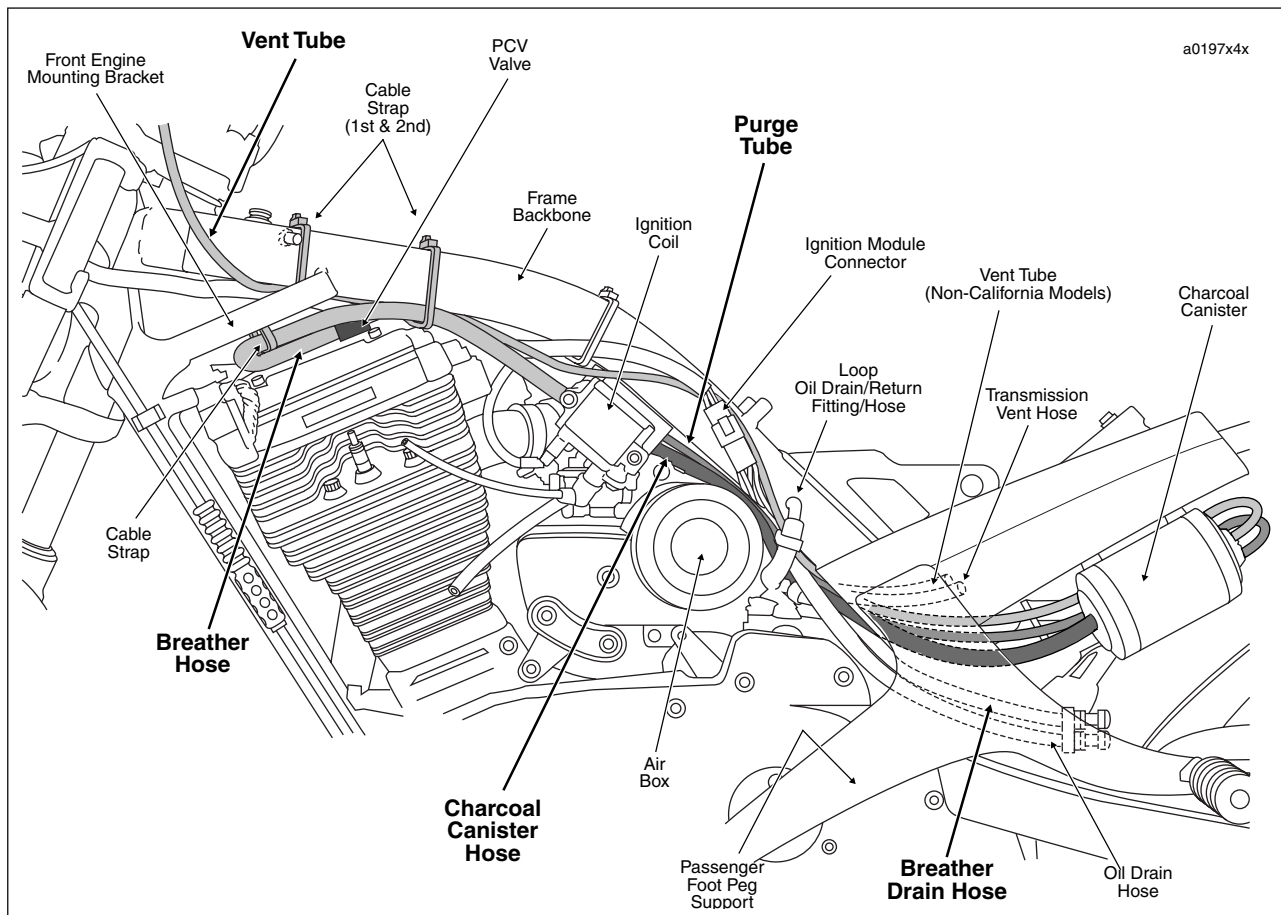

Figure 4-29. Hose Routing (Left Side View)

